



TX-I/O™

Universal modules

TXM1.8U TXM1.8U-ML

- **Two fully compatible versions:**
 - TXM1.8U: 8 inputs/outputs with LED signal / fault indication
 - TXM1.8U-ML: As TXM1.8U, but with additional local override facility with LCD display (LO/ID to ISO 16 484-2)
- **8 universal I/O points, individually configurable as**
 - Digital input: maintained contact, pulse or counter
 - Analog input: sensor, 0..10V
 - Analog output: 0..10V
- **Compact DIN format, small footprint**
- **Separate terminal base and plug-in I/O module for convenient handling**
 - Self-establishing bus connection for maximum ease of installation
 - Terminal isolation function for fast commissioning
 - I/O module replaceable in seconds, without rewiring and without affecting the full functioning of the remaining I/O modules
- **All terminals are directly on the I/O modules, allowing direct connection of field devices without additional terminal strips.**
- **Simple strategy for operation and display**
 - I/O status LED for each I/O point; mode of operation (N/C or N/O) and brightness depend on I/O function
 - LEDs and LCD for fast diagnostics
- **Double-sided labels for identification of all I/O points**

Functions

The modules support the following I/O functions:

Function	Signal type	Signal type	Description
Status signal	BI NO	D20	Volt-free, interrogation (maintained contact), N/O contact
	BI NC	D20R	Volt-free, interrogation (maintained contact), N/C contact
Status pulses	BI Pulse NO BI Pulse NC	D20S	Volt-free, interrogation (pulse), N/O, N/C contact
Counter pulses	CI EI (100Hz)	C	Volt-free, N/O contact, interrogation (pulse)
	CI Mech (10/25Hz)		Counting frequency max. 100 Hz (electronic counter) max. 25 Hz (mechanical counter)
Voltage, resistance and temperature	AI 0-10V	U10	DC voltage 0 ... 10 V
	AI 2500 Ohm	R2K5	Resistance 2500 Ω
	AI Ni1000 extended	Ni1K	Temperature sensor LG-Ni 1000 ohms, up to 180 °C
	AI Ni1000	R1K	Temperature sensor LG-Ni 1000 ohms
	AI PT1K375	Pt1K 375	Temperature sensor Pt 1000 (USA)
	AI PT1K385	Pt1K 385	Temperature sensor Pt 1000 (Europe)
	AI Pt1000	P1K	Resistance Pt 1000 ohms and resistance transmitter
	AI T1 (PTC)	T1	Temperature sensor PTC
	AI NTC10K	NTC10 K	Temperature sensor NTC 10 K
AI NTC100K	NTC100 K	Temperature sensor NTC 100 K	
Proportional output signal	AO 0-10V	Y10S	Proportional control output, DC 0 ... 10 V, with storage of control value

For a detailed description of these functions, please refer to document CA110561, "TX-I/O™ functions and operation".

Compatibility

Support of signal types and functions in different building automation and control systems: see TX-I/O Engineering and installation manual, CM110562.

Type summary

ASN

Universal module **TXM1.8U**

Universal module **TXM1.8U-ML** with LCD display and local override

Delivery

The terminal base and the electronic plug-in unit are interconnected and delivered in the same box.

Accessories

The available accessories include address keys, label sheets, and spare transparent label holders. Refer to data sheet CM2N8170.

For a description of the features common to all TX-I/O™ modules, please refer to the TX-I/O™ Engineering and installation manual, document CM110562.

Indicators and operator controls

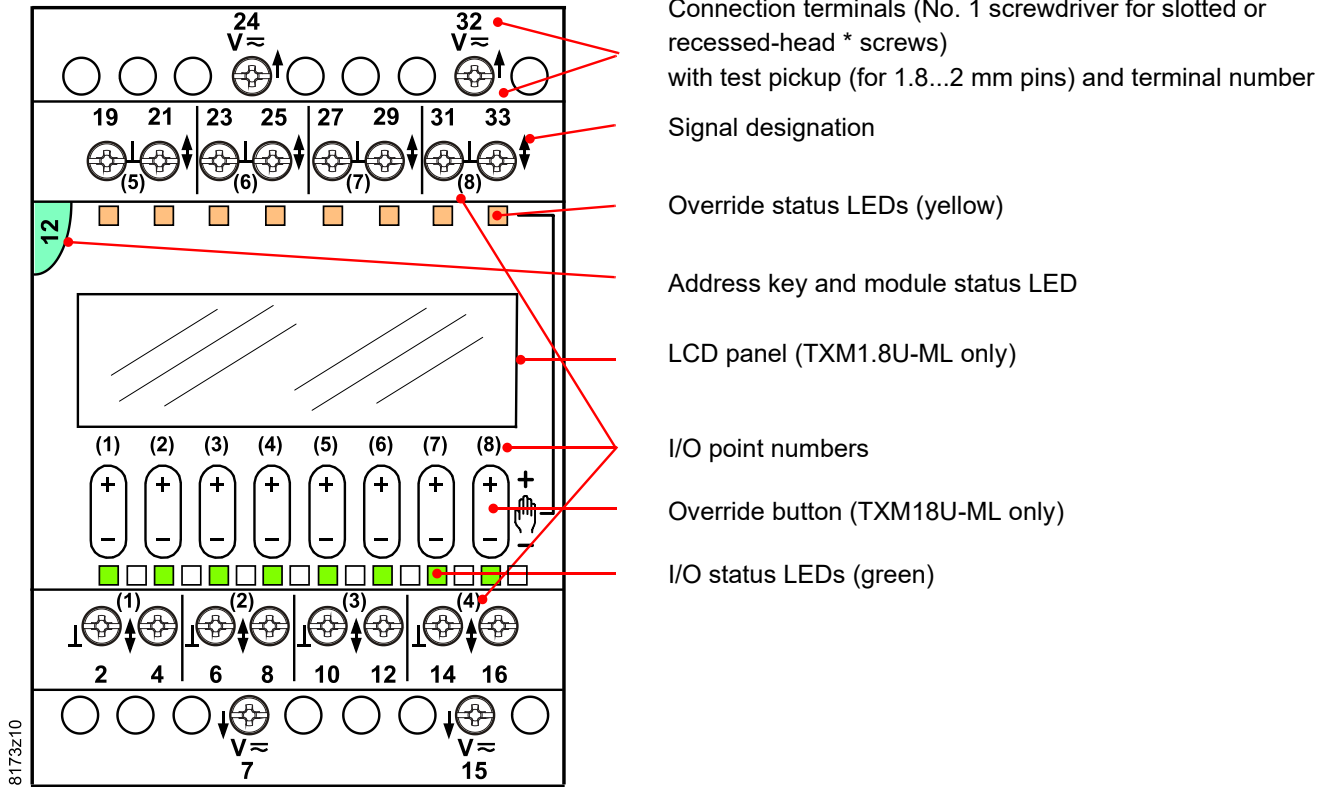

* Combined slotted / recessed-head screws from mid-2012

I/O status LEDs

- The I/O status LEDs (green) indicate the status of the inputs and outputs (peripheral devices)
- They are also used for diagnostics

Module status LED

- The module status LED illuminates the transparent address key
- The LED (green) shows the module status as a whole (as opposed to the status of the I/O points)
- It is also used for diagnostics

Address key

- The module operates only with the address key inserted
- The module address is mechanically encoded in the address key
- When replacing the I/O module, the address key must be swiveled outward. It remains plugged into in the terminal base.

Local override and LCD display (TXM1.8U-ML only)

For a detailed description, please refer to document CM110561, "TX-I/O™ Functions and operation".

Override button

- Pressing an override button in the middle enables or disables the local override
- Pressing "+" or "-" respectively increases or reduces the output value.
- Only outputs can be overwritten. Any attempt to overwrite an input results in an error indication.

Override status LED

- The yellow "Override" LED indicates that local override is active

LCD display

- The following information is displayed for each I/O point:
 - Configured signal type
 - Symbolic display of process value
 - Information for diagnostics.
- **All safety-relevant functions must be implemented with external solutions**
- **The local override must not be used for safety shutdown operations**
- **In compliance with the standard (ISO 16 484-2, Section 3.110), the module executes all local overrides directly, without safety precautions or interlocks.**
→ **Full responsibility lies with the operator.** ←



Warning

Module labeling

The plug-in I/O module has a removable transparent cover (the label holder) for insertion of a label.

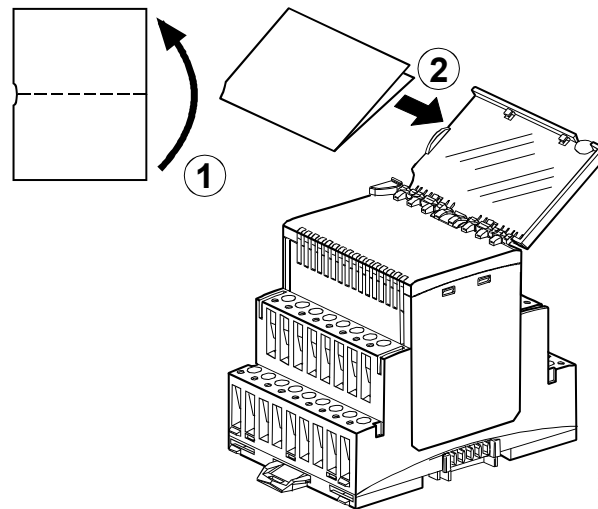

Disposal



This symbol or any other national label indicates that the product, its packaging, and, where applicable, any batteries may not be disposed of as domestic waste. Delete all personal data and dispose of the item(s) at separate collection and recycling facilities in accordance with local and national legislation.

For additional details, refer to www.siemens.com/bt/disposal

Please refer to the following documents

Document	Number
TX-I/O™ functions and operation	CM110561
TX-I/O™ Engineering and installation manual	CM110562
Replacement of legacy modules	CM110563



Mounting

Permitted orientation

The TX-I/O™ devices can be installed in any orientation:

It is important to provide adequate ventilation so that the admissible ambient temperature (max. 50°C) is not exceeded.

Technical data

Supply (bus connector on side)	Operating voltage range	DC 21.5 ... 26 V (SELV / PELV) or DC 24 V class 2 (US)			
	Max. power consumption	<table border="0"> <tr> <td>TXM1.8U</td> <td>1.5 W</td> </tr> <tr> <td>TXM1.8U-ML</td> <td>1.8 W</td> </tr> </table> <p>(for the sizing of power supplies, see CM110562)</p>	TXM1.8U	1.5 W	TXM1.8U-ML
TXM1.8U	1.5 W				
TXM1.8U-ML	1.8 W				
Protection	All terminals of the modules	Against shortcut and incorrect wiring with AC / DC 24 V			
	Bus connector on side	No protection!			
Field devices	The of the connected field devices against mains voltage must comply with the requirements for safety extra-low voltage (SELV) or protection by extra-low voltage (PELV) as per HD 384.				
Measuring cables	Cable material	Solid or stranded copper wire			
	Cable cross section	See manual CM110562			
	Permitted cable length	max. 300 m			
AC/DC output (field supply)	Voltage	AC / DC 12 ... 24 V			
	Admissible current per module	Max. 4 A (total for all 4 terminals)			
( , Terminals 7, 15, 24, 32)	Fuse	T 10A, in power supply module/bus connection module			
 Caution!	Wiring of the AC/DC 24 V supply: Use cable cross section suited for 10 A according to local regulations.				
Digital inputs / counter inputs	<p>Digital inputs are not electrically separated from the system electronics. Mechanical contacts must be volt-free. Electronic switches must comply with SELV / PELV standards. <i>Counter inputs faster than 1 Hz that are routed for more than 10 m in the same trunking as analog inputs must be shielded.</i></p>				

Contact sensing voltage	DC 21.5 ...25 V
Contact sensing current	1.0 mA (initial current 6 mA)
Contact resistance with contacts closed	Max. 200Ω
Contact resistance with contacts open	Min. 50kΩ

	Min. closing / opening time [ms] including bouncing	Max. bounce time [ms]	Max. Counting frequency (symmetric)
Maintained contact	60	20	
Pulse contact	30	10	
Mechanical counter	20	10	25 Hz
electronic counter	..5	..0	100 Hz
counter memory	0...4.3 x 10 ⁹ (32 bit counter)		

Analog inputs

Correction of line resistance	1 Ω (calibrated In module)
-------------------------------	----------------------------

	Signal type (see page 2)	Range	Under / over range	Resolution
Resistance Pt 1000 and resistance transmitter	P1K	0...2500 Ohm	0...2650 Ohm	100 mOhm
	AI Pt1000	0...2500 Ohm	0...2650 Ohm	100 mOhm
Temp. measurement	AI PT1K 375	-50...180	-52.5...185.0 °C	10 mK
	AI PT1K 385 ¹⁾	-50...400 (600) °C ¹⁾	-52.5...610 °C	20 mK
	AI NI1000 extended ¹⁾	-50...150 (180) °C ¹⁾	-52.5...185.0 °C	10 mK
	AI Ni1000	-50...150 °C	-52.5...155.0 °C	10 mK
	AI T1 (PTC) ¹⁾	-50...130 (150) °C ¹⁾	-52.5...155.0 °C	10 mK
	AI NTC10K ¹⁾	(-40...115 °C) ¹⁾	-52.5...155 °C	10 mK (25 °C)
	AI NTC100K ¹⁾	(-40 ...125 °C) ¹⁾	-52.5...155 °C	10 mK (25 °C)

1) 180 °C, 600 °C, NTC: only with reduced hum injection

Voltage measurement	AI 0-10V ²⁾	0 ... 10 V ²⁾	-1.5...11.5 V	1 mV
---------------------	------------------------	--------------------------	---------------	------

2) In case of open connection: negative voltage -3.1 V, 0.05 mA (open circuit detection)

Analog outputs

	Signal type	Range	Under / over range	Resolution
Output voltage	AO 0-10V	0 ... 10 V	-0.05...10.6 V	1 mV
Output current		max. 1 mA		

Connection terminals

Mechanical design	Rising cage terminals
Solid conductors	1 x 0.5 mm ² to 4mm ² or 2 x 0,6 mmØ to 1.5 mm ²
Stranded conductors without connector sleeves	1 x 0.5 mm ² to 2.5 mm ²
Stranded conductors with connector sleeves (DIN 46228/1)	or 2 x 0,6 mmØ to 1.5 mm ² 1 x 0.25 mm ² to 2.5 mm ² or 2 x 0,6 mmØ to 1.5 mm ²
Screwdriver	No. 1 Screwdriver for slotted or recessed-head * screws <i>with shaft diameter ≤ 4.5 mm</i> * Combined slotted / recessed-head screws from mid-2012
Max. tightening torque	0.6 Nm

Test pickups (test terminals)	For pin diameter	1.8 ... 2.0 mm
Local override (TXM1.8U-ML only)	Local override / indication device	ISO 16 484-2, Section 3.11
Classification to EN 60730	Mode of operation of automatic electrical controls	Type 1
	Contamination level	2
	Mechanical design	Protection class III
Housing protection standard	Protection standard to EN 65029	
	Front-plate components in DIN cut-out Terminal base	IP30 IP20
Ambient conditions	Operation	As per IEC/EN 60721-3-3
	Climatic conditions	Class 3K23
	Temperature	-5...50 °C
	Humidity	5...95 % rh
	Mechanical conditions	Class 3M11
	Transport / storage	As per IEC/EN 60721-3-2 /-3-1
	Climatic conditions	Class 2K12 / 1K22
	Temperature	-25...70 °C
	Humidity	5...95 % rh
Mechanical conditions	Class 2M4	
Standards, directives and approvals	Product standard	EN 60730-1
	Electromagnetic compatibility (Applications)	Automatic electrical controls for household and similar use For use in residential, commercial, light-industrial and industrial environments
	EU conformity (CE)	See EU declaration of conformity*)
	UL certification (US)	UL 916, UL 864, http://ul.com/database
	CSA certification	Class 4812 https://www.csagroup.org/services-industries/product-listing/
	RCM-conformity (EMC)	See RCM declaration of conformity*)
	EAC conformity	Eurasia conformity
Environmental compatibility	Product environmental declaration (contains data on RoHS compliance, materials composition, packaging, environmental benefit, disposal)	CM2E8173 *)
Color	Plug-in I/O module and terminal base top	2003 Ti-Grey
	Terminal base bottom	804 Black
Dimensions	Housing to DIN 43 880, see "Dimensions"	
Weight	Without / with packaging	TXM1.8U 179 / 200 g
		TXM1.8U-ML 202 / 223 g

*) The documents can be downloaded from <http://siemens.com/bt/download>.

Connection diagrams (examples)

Digital inputs

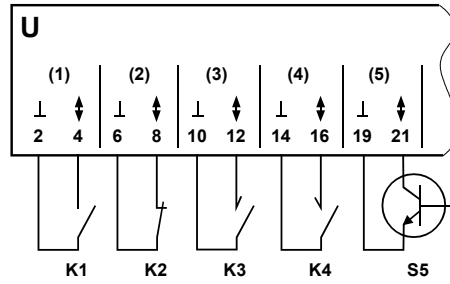

- U** Universal module
- K1** Status contact (N/O)
- K2** Status contact (N/C)
- K3** Pulse contact (N/O)
- K4** Pulse contact (N/C)
- S5** Electronic switch

8174z13

Terminal layout

I/O point	TXM1.8U, TXM1.8U-ML							
	(1)	(2)	(3)	(4)	(5)	(6)	(7)	(8)
System neutral \perp (-) ¹⁾	2	6	10	14	19	23	27	31
Input \updownarrow (+)	4	8	12	16	21	25	29	33

Counter inputs

Counter inputs faster than 1 Hz that are routed for more than 10 m in the same trunking as analog inputs must be shielded.

Analog inputs

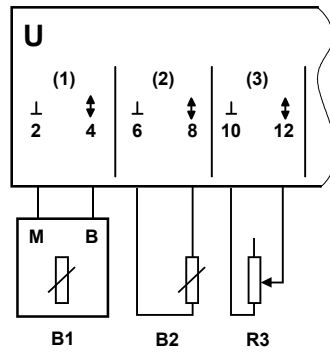

- U** Universal module
- B1** LG-Ni 1000 temperature sensor
- B2** Pt 1000 temperature sensor
- R3** Resistance-type sensor
- B4** Active sensor with external supply
External supply must NOT be earthed (earth loop)
- B5** Active sensor with AC / DC supply

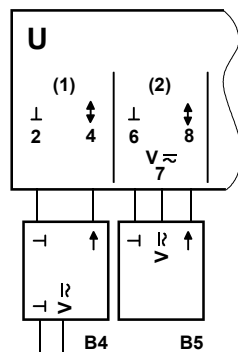

8173z14

Terminal layout

I/O point	TXM1.8U, TXM1.8U-ML							
	(1)	(2)	(3)	(4)	(5)	(6)	(7)	(8)
Measuring neutral \perp (-) ¹⁾	2	6	10	14	19	23	27	31
Input \updownarrow (+)	4	8	12	16	21	25	29	33
AC / DC sensor supply voltage ²⁾	Selected from: 7, 15, 24, 32 ²⁾							

Analog outputs

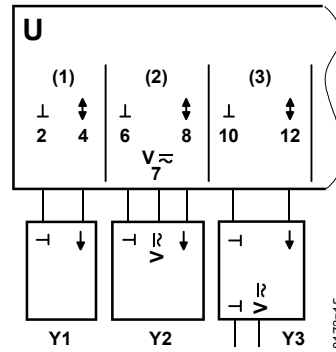

- U** Universal module
- Y1** Actuator with input DC 0 ..10 V
- Y2** General device with input DC 0 ..10 V, supplied by module
- Y3** General device with input DC 0 ..10 V, supplied externally
External supply must NOT be earthed (earth loop)

Terminal layout

I/O point	TXM1.8U, TXM1.8U-ML							
	(1)	(2)	(3)	(4)	(5)	(6)	(7)	(8)
System neutral \perp (-) ¹⁾	2	6	10	14	19	23	27	31
Output \updownarrow (+)	4	8	12	16	21	25	29	33
AC / DC operating voltage ²⁾	Selected from: 7, 15, 24, 32 ²⁾							

- 1) All measuring / system neutral terminals are interconnected, not in the terminal base but in the plug-in I/O module. When this unit is pulled outward (into the "parking" position) there is no connection.
 - The system neutral of a **digital input** can be connected to any system neutral terminal
 - With **analog inputs and outputs**, the measuring / system neutral must always be connected to the terminal associated with that I/O point.
- 2) All **AC/DC** 24V supply terminals are interconnected (in the I/O module, not in the terminal base). They are protected in the power supply module / bus connection module (T10A). Wiring of the AC/DC 24 V supply (terminals 7, 15, 24, 32):
Use cable cross section suited for 10 A according to local regulations.

Caution!

For wiring details refer to the TX-I/O™ Engineering and installation manual, CM110562.

Dimensions

Dimensions in mm

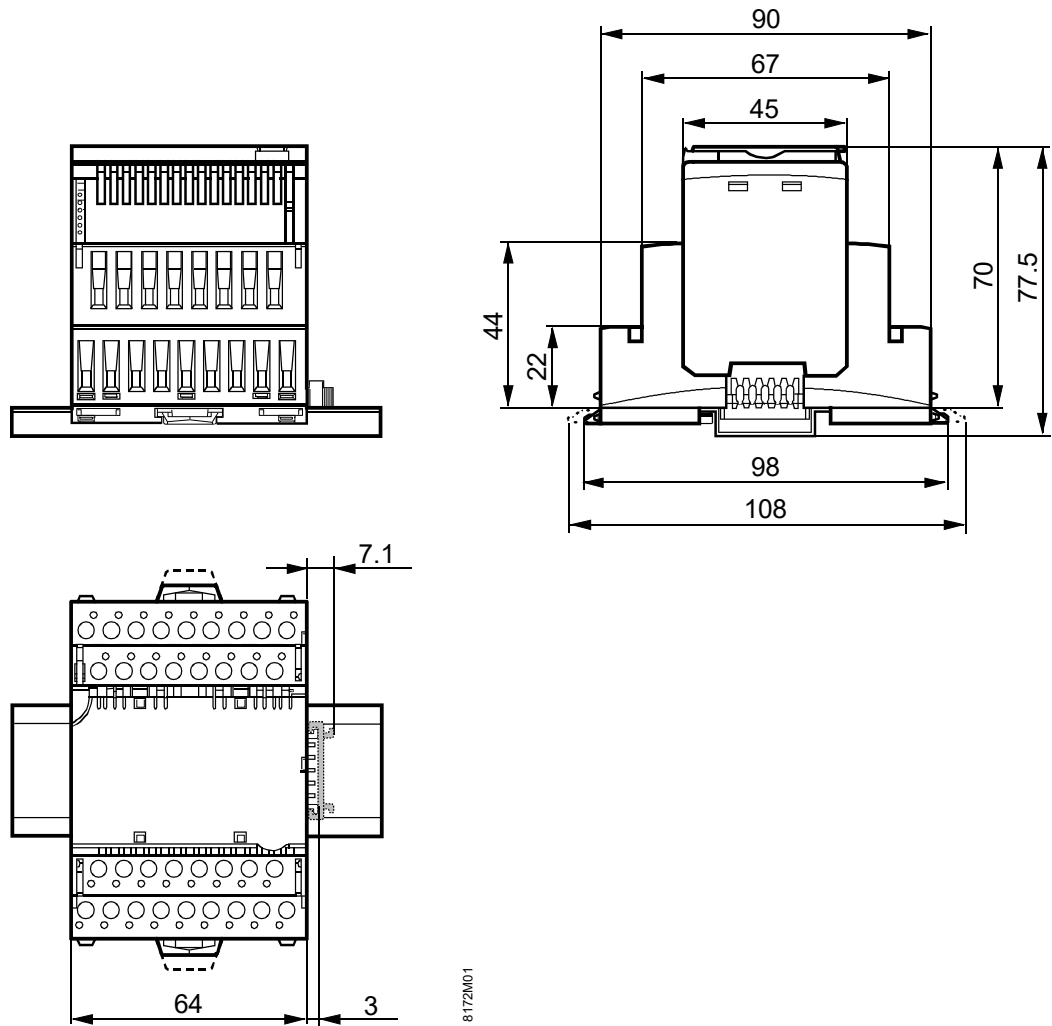

Published by:
Siemens Switzerland Ltd.
Smart Infrastructure
Global Headquarters
Theilerstrasse 1a
6300 Zug
Switzerland
Tel. +41 58-724 24 24
www.siemens.com/buildingtechnologies

© Siemens Switzerland Ltd 2007
Delivery and technical specifications subject to change