



TX-I/O™

Blinds module

TXM1.8RB

- 8 non-floating relay outputs for...
 - 4 blinds motors with 2 end switches, or
 - 2 blinds motors with 3 end switches, or
 - 2 blinds motors with 2 end switches
+ 1 blinds motor with 3 end switches
- Switching voltage AC 100...250 V
- Green status LED to indicate status for each I/O point
- Current measurement for each blinds motor for end position detection
- Compact design as per DIN, requiring little space
- Separation into terminal base and electronics unit for optimal handling
 - Self-connecting bus for the easiest possible installation
 - Isolating terminal function for fast commissioning
 - Exchange of electronics unit within seconds without a need of rewiring, at full functionality of the remaining I/O modules
- Terminal strips are required to connect N and PE of the field devices
- Simple display concept
 - Lit I/O status LEDs for the outputs when relays are active
 - LEDs for fast fault diagnosis
- Double-sided labeling of all I/O points with label

Functions

The module supports the following I/O function:

Signal type	Description
BO Blind Relay	Maintained contact relay, for blinds control with 2 / 3 end switches

See document "TX-I/O™ Functions and operation", CM110561, for a detailed description of this function.

Compatibility

For signal type support and functionality in the various building automation and control systems, see TX-I/O™ engineering and installation manual, CM110562.

Ordering

Type	Stock number	Designation
TXM1.8RB	S55661-J105	Blinds module

Delivery

Terminal base and electronics unit are assembled and delivered in a box.

Accessories

Address keys, printable label sheets and replacement label holders are available as accessories. See data sheet CM2N8170.

Design and technology

See the TX-I/O™ Engineering and installation manual, CM110562, for a description of the properties for all TX-I/O™ modules.

Operating and display elements

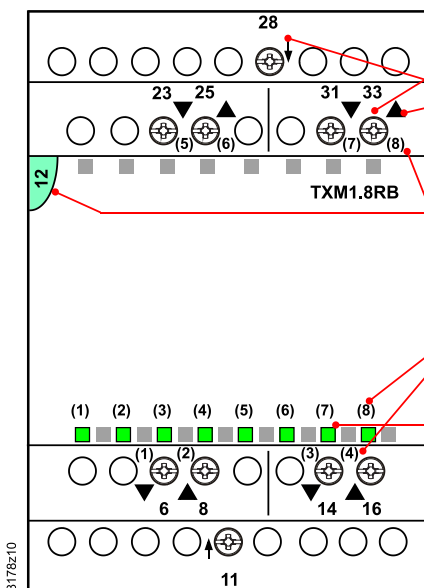

Connection terminals (No. 1 screwdriver for slotted or recessed-head * screws) with test plug socket (pins 1.8 to 2 mm) and terminal number.

Signal designation

Address key and module status LED

I/O point numbers

Output status LEDs (TXM1.8RB: green)

* Combined slotted / recessed-head screws from mid-2012

Output status LEDs

- The output status LEDs indicate the relay status. The LEDs are also used for diagnostics.

Module status LED

- The module status LED illuminates the transparent address key.
- The LED (green) indicates the status for the entire module (contrary to the I/O point status).
- It can also be used for diagnostic purposes.

Address key

- The module only works with the address key.
- The module address is mechanically encoded in the address key.
- Swing out the address key when exchanging the electronics unit. The key remains in the terminal base.

Terminal

- The relay contact lines are interconnected (in the electronics unit). Active mains power must be supplied separately to each terminal strip.
- Different phases for the different terminals strips are allowed.

End position detection

- The end position of the blind is detected using a current measurement. Measurement reports "On" when the motor exceeds a minimum current / motor power (see technical data).

Module labeling

The electronics unit has a removable, transparent lid (label holder) allowing for insertion of the label.

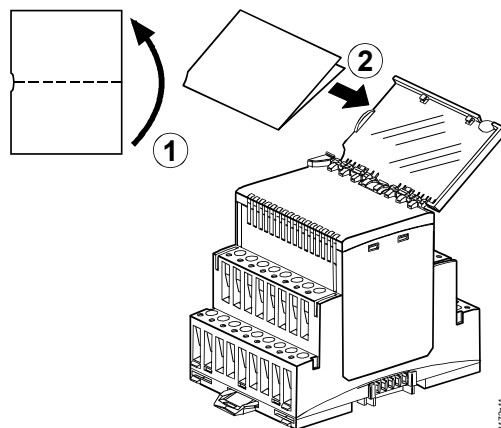

Disposal



This symbol or any other national label indicates that the product, its packaging, and, where applicable, any batteries may not be disposed of as domestic waste. Delete all personal data and dispose of the item(s) at separate collection and recycling facilities in accordance with local and national legislation. For additional details, refer to www.siemens.com/bt/disposal.

Please consult the following documents:

Document	Number
TX-I/O™ Functions and operation	CM110561
TX-I/O™ Engineering and installation manual	CM110562

Mounting

Allowed mounting positions

TX-I/O™ devices can be mounted in any position:

You must ensure, however, that sufficient ventilation is available to maintain the permissible ambient temperature (max. 50°C).

Technical data

Power supply (side bus connector)	Operating voltage	DC 21.5 ... 26 V
	Safety extra-low voltage SELV or protection by extra-low voltage PELV per HD384	
	Max. power consumption (see CM110562 for supply design)	1.4 W
Protection	Bus connector on side	No protection against shortcut and incorrect wiring with AC / DC 24 V
Switching outputs	Number of switching outputs	8 (NO contacts)
	External supply line fusing	
	<ul style="list-style-type: none"> • Non-renewable fuse, slow • Miniature circuit breaker MCB 	Max. 10 A Max. 13 A
	Tripping characteristic MCB	B, C, D as per EN 60898
	Contact data	
	Switching voltage	Max. AC 100 to 250 V
	Motor current	Max. 3 A
	⚠ *) Switch-on current (max. 1 s *)	Max. 10 A *)
	Minimum current	Min. 1 mA at AC 250 V
	Pickup/dropout time	7 ms / 3 ms typical
Current measurement	"On"	$I \geq 0.2 \text{ A}$
	"Off"	$I \leq 0.1 \text{ A}$
Contact life for AC 250 V (guide values)	Up to 2 A	1×10^5 switchings
	Up to 3 A	5×10^4 switchings
	Insulating strength	AC 3000 V, as per EN 60730-1
	Between relay outputs and system electronics (increased insulation)	

*) **Caution:** Some motor manufacturers do not comply with these specifications (very short switch-on current peaks >10 A).

This is not always stated in the data sheets. For customer projects, clarify the type and properties of motors in an early phase. If in doubt, investigate or perform tests / measurements.

This applies for blinds motors as well as linear actuators for window applications.

Connection terminals	Mechanical design	Screw-type terminal
	Wire	1 x 0.5 mm ² to 4mm ² or 2 x 0.6 mm dia. to 1.5 mm ²
	Copper stranded wire without ferrules	1 x 0.5 mm ² to 2.5 mm ² or 2 x 0.6 mm dia. to 1.5 mm ²
	Stranded wire with ferrule (DIN 46228/1)	1 x 0.25 mm ² to 2.5 mm ² or 2 x 0.6 mm dia. to 1.5 mm ²
	Screwdriver	No. 1 Screwdriver for slotted or recessed-head * screws <i>with shaft diameter ≤ 4.5 mm</i> * Combined slotted / recessed-head screws from mid-2012
	Max. tightening torque	0.6 Nm
Test plug socket (test terminals)	Pin diameter	1 x 1.8 to 2.0 mm
Classification per EN 60730	Operation of automatic controller	Type 1
	Degree of pollution	2
	Mechanical design	Devices suited for use with equipment of safety classes I and II
Housing protection type	Degree of protection as per EN 60529	
	Front parts in DIN excerpt	IP30
	Terminal part	IP20
Environmental conditions	Operation	As per IEC/EN 60721-3-3
	Climatic conditions	Class 3K23
	Temperature	-5...50 °C
	Relative humidity	5...95% r.h.
	Mechanical conditions	Class 3M11
	Transport / storage	As per IEC/EN 60721-3-2 /-3-1
	Climatic conditions	Class 2K12 / 1K22
Temperature	-25...70 °C	
Relative humidity	5...95% r.h.	
Mechanical conditions	Class 2M4	
Standards and directives	Product standard	EN 60730-1
	EU conformity (CE)	See EU declaration of conformity *)
	Electromagnetic compatibility	For residential, commercial and industrial environments
	RCM conformity (EMC)	See RCM declaration of conformity*)
	UL approbation	UL 916
	*) The documents can be downloaded from http://siemens.com/bt/download .	
Environmental compatibility	Product environmental declaration (contains data on RoHS compliance, materials composition, packaging, environmental benefit, disposal)	CM1E8178
Color	Plug-in I/O module and terminal base top	2003 Ti-Grey
	Terminal base bottom	804 Schwarz
Dimensions	Housing as per DIN 43880, see dimensions	
Weight	With/without packaging	208 / 229 g

Connection diagrams (example)

Terminal assignment

Output	TXM1.8RB							
	(1)	(2)	(3)	(4)	(5)	(6)	(7)	(8)
Supply line *)	11				28			
NO contact	6 ▼	8 ▲	14 ▼	16 ▲	23 ▼	25 ▲	31 ▼	33 ▲

*) Different phases allowed for terminals 11 and 28

Blinds with 2 end switches

2 blinds can be connected per terminal strip

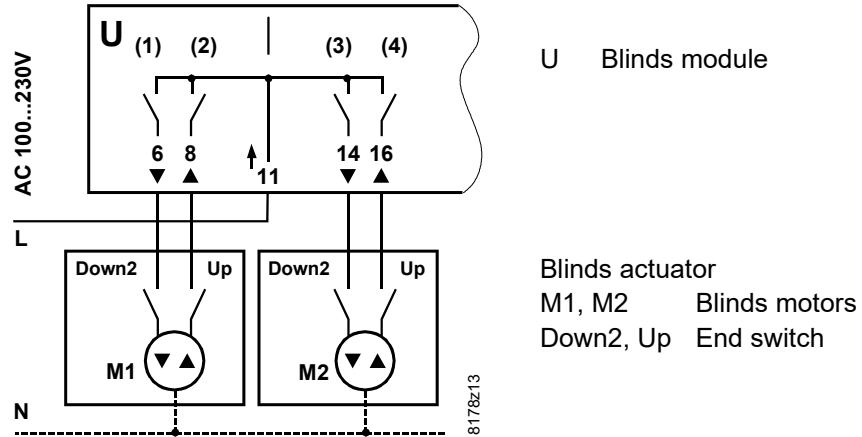

Blinds with 3 end switches

1 set of blinds can be connected per terminal strip
(the 4th terminal must remain free)

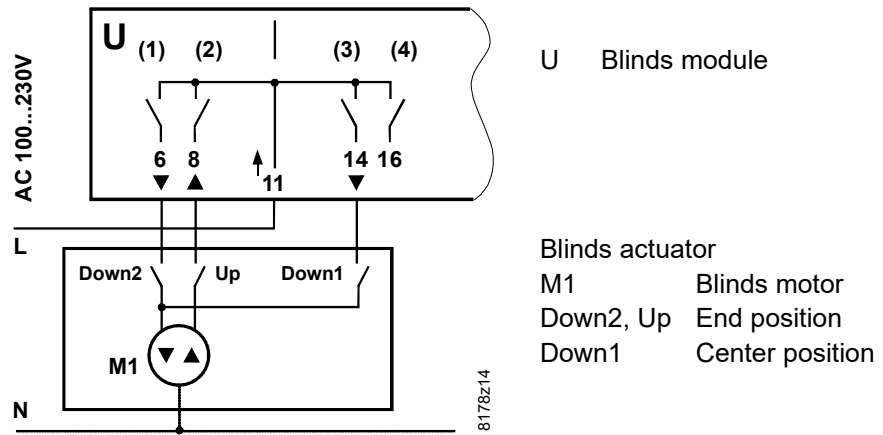

Note!

- Because of the current measurement, interposing relays for the control of several blinds in parallel are not admitted.
- **Parallel operation of more than one blinds motor on the same terminal is not admissible!**

Dimensions

Dimensions in mm

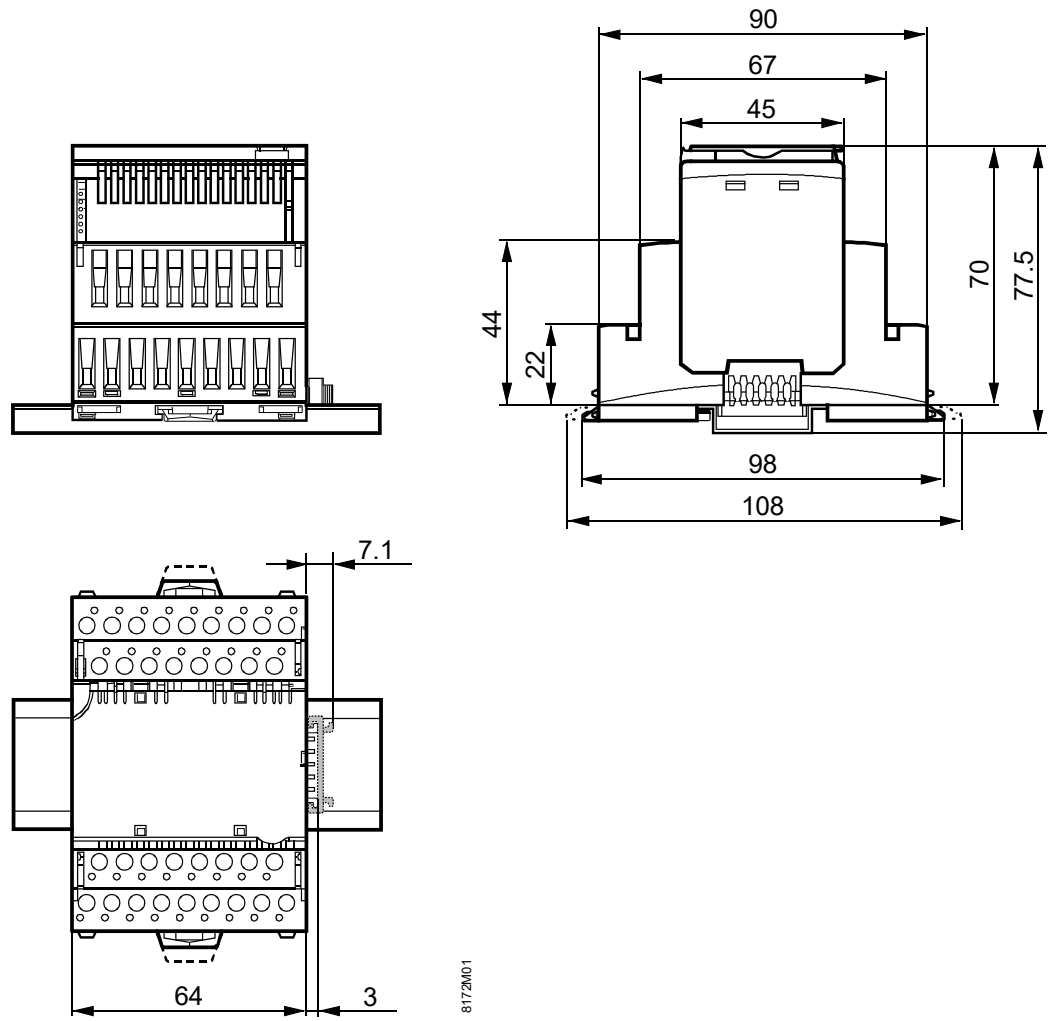

Published by:
Siemens Switzerland Ltd.
Smart Infrastructure
Global Headquarters
Theilerstrasse 1a
6300 Zug
Switzerland
Tel. +41 58-724 24 24
www.siemens.com/buildingtechnologies

© Siemens Switzerland Ltd 2012
Delivery and technical specifications subject to change