



TX-I/O™

Resistance measuring module

TXM1.8P

- 8 inputs with LED signal / fault display.
- 8 resistance measuring inputs with individual configuration of resistance or temperature measurement.
- Made especially for temperature sensors Pt100 4-wire-
- Compact design per DIN, requires little space.
- Separation into terminal base and electronics unit for optimal handling.
 - Self-connecting bus for the easiest possible installation.
 - Disconnection terminal function for fast commissioning.
 - Exchange of electronics unit within seconds without a need of rewiring, at full functionality of the remaining I/O modules.
- All terminals are connected directly to the modules, no additional terminal strips for direct connection of field devices.
- Simple display concept
 - One I/O status LED per I/O point, brightness as per input level.
 - Module status LED for quick fault diagnosis.
- Double-sided labeling of all I/O points with label.

Functions

The modules support the following I/O functions:

| Function | Signal type (TRA) | Signal type | Description | Connection |
|-----------------------------|--------------------|-------------|---|----------------------|
| Resistance and temperatures | AI PT100 4-Wire | PT100_4 | Temperature sensor Pt 100 Ohm | 4-wire ¹⁾ |
| | AI Pt100 | P100 | Resistance Pt 100 Ohm and resistance transmitter | 4-wire ¹⁾ |
| | AI 250Ohm | R250 | Resistance 250 Ohm | 2-wire |
| | AI PT1K375 | Pt1K 375 | Temperature sensor Pt1000 Ohm (USA,) | 2-wire |
| | AI PT1K385 | Pt1K 385 | Temperature sensor Pt1000 Ohm (Europe) | 2-wire |
| | AI Ni1000 | R1K | Temperature sensor LG-Ni 1000 Ohm | 2-wire |
| | AI Pt1000 | P1K | Resistance Pt 1000 Ohm and resistance transmitter | 2-wire |
| | AI Ni1000 extended | Ni1K | Temperature sensor LG-Ni 1000 Ohm | 2-wire |
| | AI 2500Ohm | R2K5 | Resistance 2500 Ohm | 2-wire |

¹⁾ An open circuit of a single conductor cannot be detected for this signal type.

See document "TX-I/O™ Functions and operation", CM110561, for a detailed description of all functions.

Compatibility

Support of signal types and functions in different building automation and control systems: see TX-I/O Engineering and installation manual, CM110562

Type summary

ASN Resistance measuring module **TXM1.8P**

Delivery Terminal base and electronics unit are inserted and delivered in a box.

Accessories Address keys, printable label sheets and replacement label holders are available as accessories. See data sheet CM2N8170.

Design and technology

See the TX-I/O™ Engineering and installation manual, CM110562, for a description of the properties for all TX-I/O™ modules.

Display elements

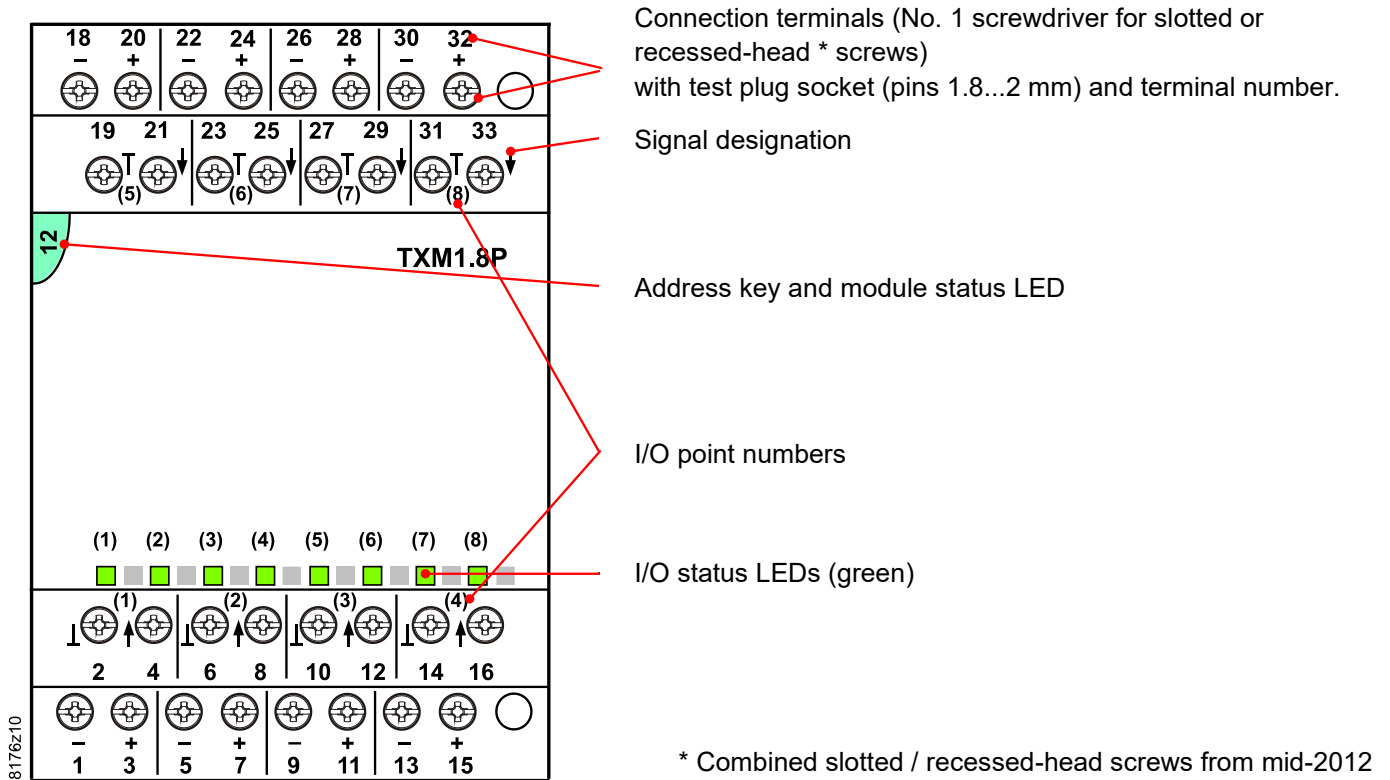

I/O status LEDs

- The I/O status LEDs (green) indicate the status of inputs/outputs (periphery).
- They can also be used for diagnostic purposes.

Module status LED

- The module status LED illuminates the transparent address key.
- The LED (green) indicates the status for the entire module (contrary to the I/O point status).
- It can also be used for diagnostic purposes.

Address key

- The module only works with the address key.
- The module address is mechanically encoded in the address key.
- Swing out the address key when exchanging the electronics unit. The key remains in the terminal base.

Module labeling

The electronics unit has a removable, transparent lid (label holder) allowing for insertion of the label.

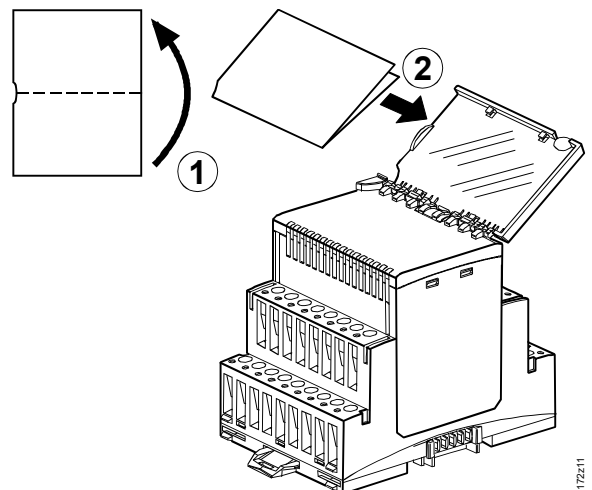

Engineering, mounting, installation

Please consult the following document:

| Document | Number |
|---|----------|
| TX-I/O™ Functions and operation | CM110561 |
| TX-I/O™ Engineering and installation manual | CM110562 |
| Replacement of legacy modules | CM110563 |

Mounting

Permissible mounting positions

TX-I/O™ devices can be mounted in any position:

You must ensure, however, that sufficient ventilation is available to maintain the permissible ambient temperature (max. 50°C).

Disposal



This symbol or any other national label indicates that the product, its packaging, and, where applicable, any batteries may not be disposed of as domestic waste. Delete all personal data and dispose of the item(s) at separate collection and recycling facilities in accordance with local and national legislation. For additional details, refer to www.siemens.com/bt/disposal.

Technical data

| | | |
|-------------------------------|--|--|
| Power (side bus connector) | Operating voltage | DC 21.5...26 V |
| | Safety extra-low voltage SELV or protection by extra-low voltage PELV per HD384 | |
| | Max. power consumption | 1.2 W |
| Protection | All module terminals | Against short circuit and incorrect wiring using AC/DC 24 V. |
| | Side bus connector | No protection! |
| Field devices | | |
| Insulating strength | The insulating strength of the connected field devices toward mains voltage must comply with the requirements for safety extra-low voltage (SELV) or protection by extra-low voltage (PELV) as per HD 384. | |
| Measuring lines | Line materials | Copper wire or copper stranded wire, unshielded |
| | Line diameter | See manual CM110562 |
| | Permissible line length | Max. 300 m |
| Analog inputs | | |
| | Correction of line resistance | 1 Ohm (calibrated in module) (0 Ohm for Pt100 4 and P100) |

| | Signal type (see page 2) | Range | Under / over range | Resolution | Sensor current |
|-------------|-----------------------------|-----------------------|--------------------|------------|----------------|
| Temperature | AI Pt100 4 wire | -50...400 (600) °C 1) | -52.5...610 °C | 20 mK | 2.1 mA |
| Resistance | AI Pt100 | 0...250 Ohm | 0...265 Ohm | 10 mOhm | 2.1 mA |
| Resistance | AI 250 Ohm (2-wire) | 0...250 Ohm | 0...265 Ohm | 10 mOhm | 2.1 mA |
| Temperature | AI PT1K375 | -50...150 (180) °C 1) | -52.5...185.0 °C | 10 mK | 1.54 mA |
| Temperature | AI PT1K385 | -50...400 (600) °C 1) | -52.5...610 °C | 20 mK | 1.96 mA |
| Temperature | AI Ni1000 extended | -50...150 (180) °C 1) | -52.5...185.0 °C | 10 mK | 1.54 mA |
| Temperature | AI Ni1000 | -50...150 °C | -52.5...155.0 °C | 10 mK | 1.54 mA |
| Resistance | AI 2500 Ohm | 0...2500 Ohm | 0...2650 Ohm | 100 mOhm | 1.96 mA |
| Resistance | AI Pt1000 | 0...2500 Ohm | 0...2650 Ohm | 100 mOhm | 1.96 mA |

1) (Extended range) *only with reduced hum injection, see CM110562*

| | | |
|----------------------|--|---|
| Connection terminals | Mechanical design | Screw-type terminal |
| | Wire | 1 x 0.5 mm ² to 4mm ² or 2 x 0.6 mmØ to 1.5 mm ² |
| | Copper stranded wire without ferrules | 1 x 0.5 mm ² to 2.5 mm ² or 2 x 0.6 mmØ to 1.5 mm ² |
| | Stranded wire with ferrule (DIN 46228/1) | 1 x 0.25 mm ² to 2.5 mm ² or 2 x 0.6 mmØ to 1.5 mm ² |
| | Screwdriver | No. 1 Screwdriver for slotted or recessed-head * screws <i>with shaft diameter ≤ 4.5 mm</i> * Combined slotted / recessed-head screws from mid-2012 |
| | Maximum stud torque | 0.6 Nm |

| | | |
|-----------------------------------|---|-------------------------------------|
| Test plug socket (test terminals) | Pin diameter | 1.8...2.0 mm |
| Classification per EN 60730 | Function of automatic control devices | Type 1 |
| | Degree of pollution | 2 |
| | Mechanical design | Protection class III |
| Housing type | Degree of protection as per EN 60529 | |
| | Front parts in DIN excerpt | IP30 |
| | Terminal part | IP20 |
| Environmental conditions | Operation | As per IEC/EN 60721-3-3 |
| | Climatic conditions | Class 3K23 |
| | Temperature | -5...50 °C |
| | Humidity | 5...95 % r.h. |
| | Mechanical conditions | Class 3M11 |
| | Transport / storage | As per IEC/EN 60721-3-2 / 3-1 |
| | Climatic conditions | Class 2K12 / 1K22 |
| | Temperature | -25...70 °C |
| | Humidity | 5...95 % r.h. |
| Mechanical conditions | Class 2M4 | |
| Standards and directives | Product standard | |
| | Automatic electronic controls for household and similar use | EN 60730-1 |
| | Electromagnetic compatibility | |
| | Immunity (domestic & industrial) | EN 60730-1 |
| | Emissions (domestic & industrial) | EN 60730-1 |
| | CE conformity | See EU declaration of conformity *) |
| | EMC Directive | 2004/108/EC |
| | RCM-conformity (EMC) | See RCM declaration of conformity*) |
| UL approbation | UL 916, UL 864 | |
| Environmental compatibility | Product environmental declaration (contains data on RoHS compliance, materials composition, packaging, environmental benefit, disposal) | CM1E8176 |
| Color | Plug-in I/O module and terminal base top | 2003 Ti-Grey |
| | Terminal base bottom | 804 Black |
| Dimensions | Housing as per DIN 43880, see dimensions | |
| Weight | Without / with packaging | 198 / 219 g |

*) The documents can be downloaded from <http://siemens.com/bt/download>.

Connection diagrams (example)

Island bus integration and PRODINET BIM

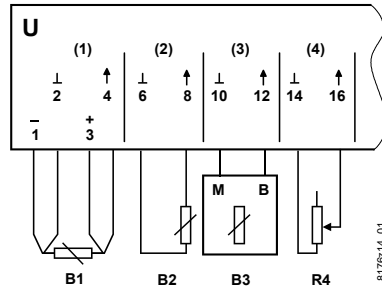

- U** Resistance measuring module
- B1** Temperature sensor Pt100 (4-wire)
- B2** Temperature sensor, general
- B3** Temperature sensor LG-Ni 1000
- R4** Resistance transmitter

Integration via P-bus interface-module TXB1.PBUS

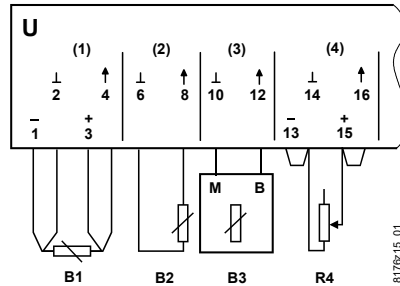

- U** Resistance measuring module
- B1** Temperature sensor Pt100 (4-wire)
- B2** Temperature sensor, general
- B3** Temperature sensor LG-Ni 1000
- R4** Resistance transmitter

Terminal assignment

| I/O points | TXM1.8P | | | | | | | |
|---------------------------------------|---------|-----|-----|-----|-----|-----|-----|-----|
| | (1) | (2) | (3) | (4) | (5) | (6) | (7) | (8) |
| ⊥ (-) Measuring neutral ¹⁾ | 2 | 6 | 10 | 14 | 19 | 23 | 27 | 31 |
| ↑ (+) Input / sensor current | 4 | 8 | 12 | 16 | 21 | 25 | 29 | 33 |
| - Measurement - (4-wire) | 1 | 5 | 9 | 13 | 18 | 22 | 26 | 30 |
| + Measurement + (4-wire) | 3 | 7 | 11 | 15 | 20 | 24 | 28 | 32 |

- ¹⁾ All measuring neutral / system neutral terminals are interconnected in the electronics unit, not the terminal base; as a result, there is no connection when the electronics unit is not in place.
With analog inputs, the measuring neutral/system neutral must always be connected to the terminal assigned to the I/O point.

Dimensions

Dimensions in mm

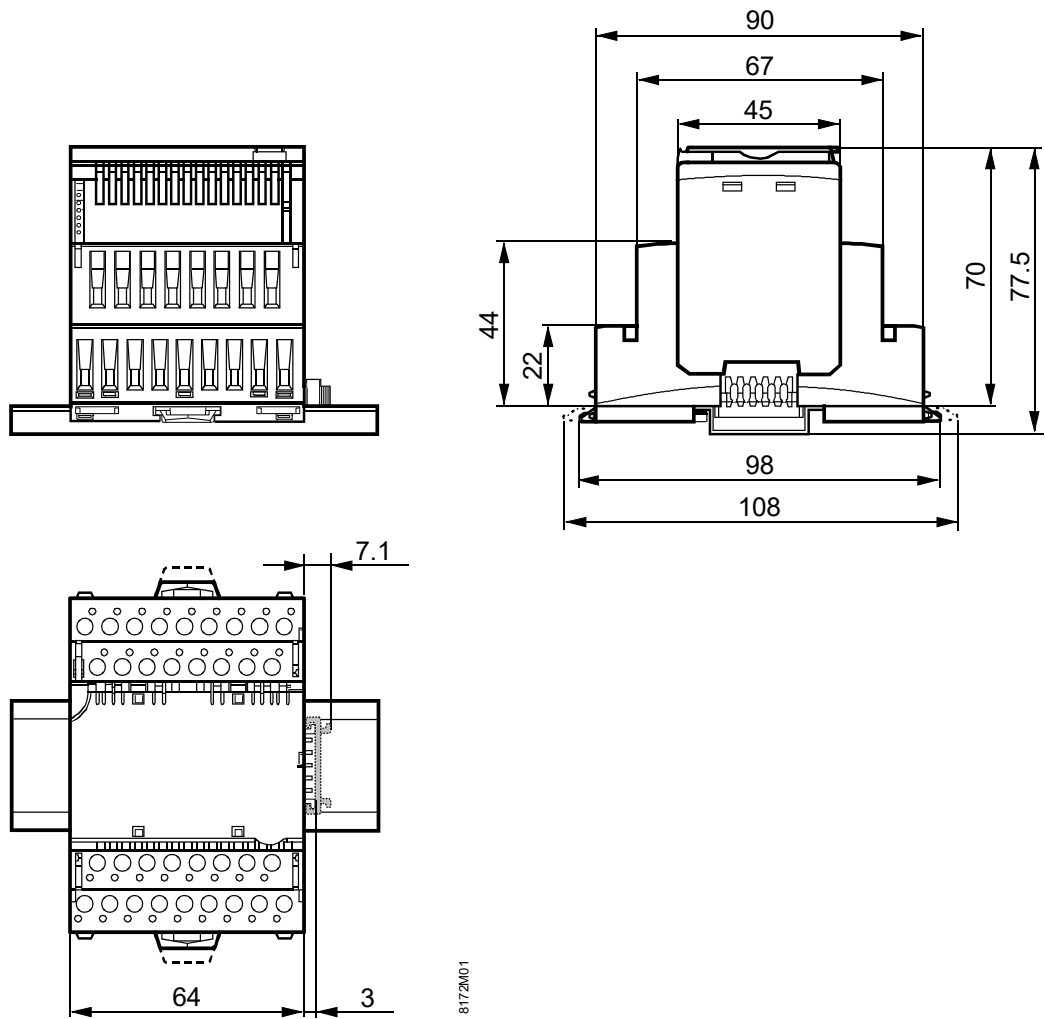

Published by:
Siemens Switzerland Ltd.
Smart Infrastructure
Global Headquarters
Theilerstrasse 1a
6300 Zug
Switzerland
Tel. +41 58-724 24 24
www.siemens.com/buildingtechnologies

© Siemens Switzerland Ltd 2009
Delivery and technical specifications subject to change