



TX-I/O™

Relay module bistable

TXM1.6RL

- Use for – Light control
 – Control of subsystems with uninterruptible operation

- 6 volt-free relay outputs, bistable
- Configurable behavior in case of power failure and bus failure
- Individual I/O point signaling with green I/O status LED
- Compact DIN format, small footprint
- Separate terminal base and plug-in I/O module for convenient handling
 - Self-establishing bus connection for maximum ease of installation
 - Terminal isolation function for fast commissioning
 - I/O module replaceable in seconds, without rewiring and without affecting the full functioning of the remaining I/O modules
- Terminal strips are required to connect N and PE of the field devices
- Simple strategy for display
 - I/O status LED for each I/O point
 - LEDs for fast diagnostics
- Double-sided labels for identification of all I/O points

Functions

The module supports the following I/O functions:

Signal type (TRA)	Signal type	Description
BO Bistable NO BO Bistable NC	Q250B	Maintained contact, single-pole, bistable N/O, N/C contact

For a detailed description of the function, please refer to document CM110561, "TX-I/O functions and operation".

Compatibility

Support of signal types and functions in different building automation and control systems: see TX-I/O Engineering and installation manual, CM110562

Type summary

ASN, SSN

Product no.	Stock no.	Designation
TXM1.6RL	S55661-J103	Relay module bistable

Delivery

The terminal base and the plug-in I/O module are interconnected and delivered in the same box.

Accessories

The available accessories include address keys, label sheets, and spare transparent label holders. Refer to data sheet CM2N8170.

Technical and mechanical design

For a description of the features common to all TX-I/O™ modules, please refer to the TX-I/O™ Engineering and installation manual, document CM110562.

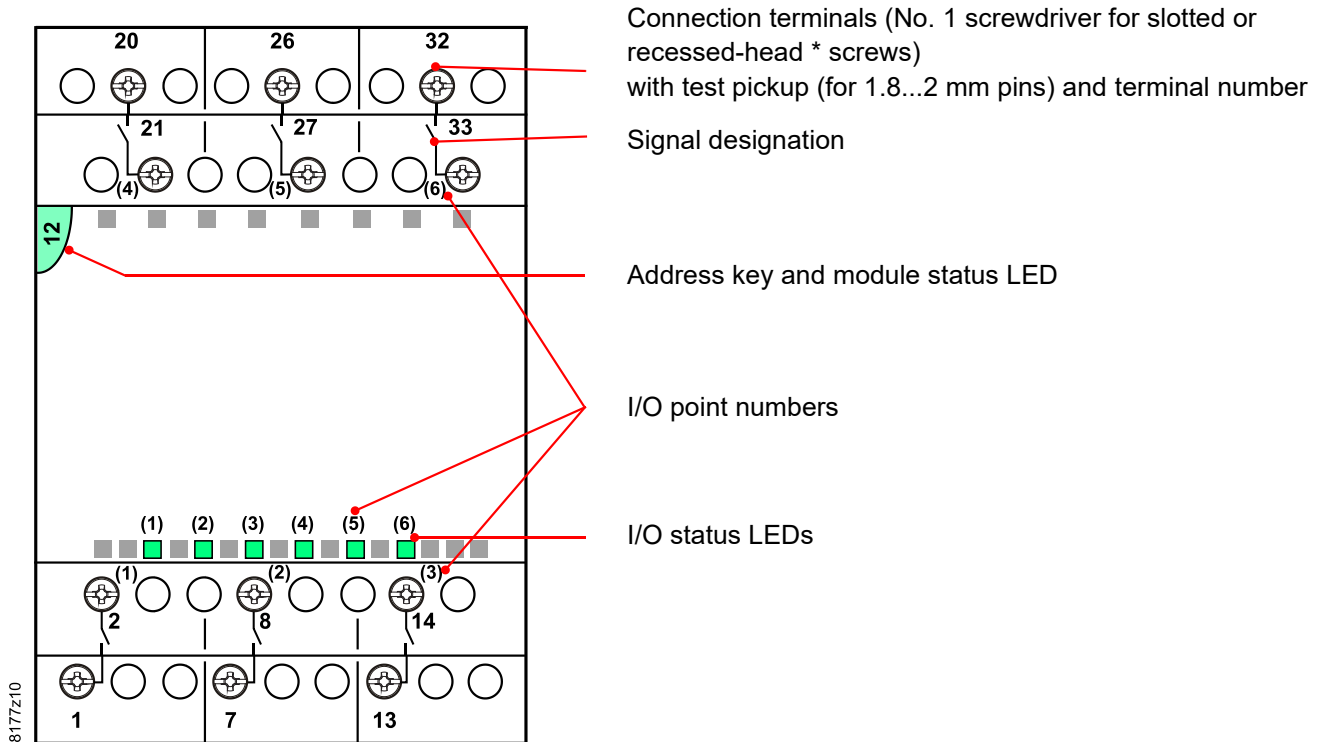

* Combined slotted / recessed-head screws from mid-2012

I/O status LEDs

- The green I/O status LEDs indicate the status of the relays
- The LEDs are also used for diagnostics

Module status LEDs

- The module status LED illuminates the transparent address key
- The (green) LED shows the module status as a whole (as opposed to the I/O points)
- It is also used for diagnostics

Address key

- The module operates only with the address key inserted
- The module address is mechanically encoded in the address key
- When replacing the plug-in I/O module, the address key must be swiveled outward. It remains plugged into in the terminal base.

Terminals

- The relay contacts of the individual I/O points are volt-free, and are not interconnected. The switched voltage must be provided separately for each I/O point.
- Mixed phases are permitted on adjacent I/O points of the module.

Note: UL916

Restriction for UL916: I/O points 1...3 and 4...6 must have the same phase.

Module labeling

The plug-in I/O module has a removable transparent cover (the label holder) for insertion of a label.

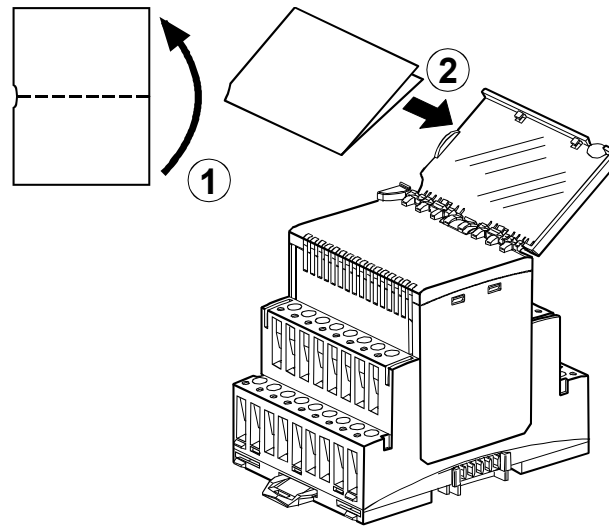

Disposal



This symbol or any other national label indicates that the product, its packaging, and, where applicable, any batteries may not be disposed of as domestic waste. Delete all personal data and dispose of the item(s) at separate collection and recycling facilities in accordance with local and national legislation. For additional details, refer to www.siemens.com/bt/disposal.

Engineering, mounting, installation and commissioning

Please refer to the following documents

Document	Number
TX-I/O™ functions and operation	CM110561
TX-I/O™ Engineering and installation manual	CM110562

Mounting

Permitted orientation

The TX-I/O™ devices can be installed in any orientation:

It is important to provide adequate ventilation so that the admissible ambient temperature (max. 50°C) is not exceeded.

Technical data

Supply (bus connector on side)	Operating voltage range	DC 21.5...26 V (SELV / PELV) or DC 24 V class 2 (US)	
	Max. power consumption <i>(for the sizing of power supplies, see CM110562)</i>	2.3 W	
Protection	Bus connector on side	No protection against shortcut and incorrect wiring with AC / DC 24 V	
Switching outputs	Number of switching outputs	6 (one pole bistable contact)	
	Contact data		
	Type	W pre-make + AgSnO ₂	
	Switching voltage	Max. AC 277 V Min. AC 24 V	
	Current rating	AC1 (cosφ=0.8) EN 60947-4-1 Life cycles (277V 50/60 Hz) AC3 (cosφ=0.45) EN 60947-4-1 Inrush current (20 μs) Inrush current (20 ms) Minimum current	Max. AC 10 A (resistive) > 30,000 switching operations Not recommended for AC3 Max. 800 A Max. 165 A Min. 100 mA at AC 24 V
	Fluorescent lamps	EN 60669-1 Life cycles (277V 50/60 Hz)	Max. 10 A (140 μF) > 30,000 switching operations
	Number of ballasts	OSRAM QTI 1x28 / 54W OSRAM QTP5 1x24 / 39W OSRAM QTP5 2x24 / 39W OSRAM QTP5 1x54W OSRAM QTP5 2x54W OSRAM QT-FIT8 1x58 / 70W OSRAM QT-FIT8 2x58 / 70W	Max. 27 Max. 33 Max. 20 Max. 20 Max. 15 Max. 42 / 36 Max. 21 / 18
		<i>Other types / other manufacturers: check if inrush currents are admissible!</i>	
	Filament lamps	Life cycles (230V, 1'500W)	> 40,000 switching operations
	External fuse protection for incoming cable		
		• Slow blow fuse • Circuit breaker	Max. 16 A Max. 16 A
		Tripping characteristic to EN 60898	Type B, C or D
	Insulation resistance	Reinforced insulation between relay outputs and system electronics Mixed phases are permitted on adjacent I/O points of the module. <i>Restriction for UL916: I/O points 1...3 and 4...6 must have the same phase.</i>	AC 3280 V, to EN 60 730-1
	Connection terminals	Mechanical design	Cage clamp terminals
		Solid conductors	1 x 0.5 mm ² to 4mm ² or 2 x 0,6 mmØ to 1.5 mm ²
Stranded conductors without connector sleeves		1 x 0.5 mm ² to 2.5 mm ² or 2 x 0,6 mmØ to 1.5 mm ²	
Stranded conductors with connector sleeves (DIN 46228/1) Screwdriver		1 x 0.25 mm ² to 2.5 mm ² or 2 x 0,6 mmØ to 1.5 mm ² No. 1 Screwdriver for slotted or recessed-head * screws <i>with shaft diameter ≤ 4.5 mm</i> * Combined slotted / recessed-head screws from mid-2012	
	Max. tightening torque	0.6 Nm	
Test pickups (terminals)	For pin diameter	1 x 1.8...2.0 mm	

Classification to EN 60730	Mode of operation of automatic electrical controls	Type 1
	Contamination level	2
	Mechanical design	The device is suitable for use in equipment with protective class I and II
Housing protection standard	Protection standard to EN 65029	
	Front-plate components in DIN cut-out	IP30
	Terminal base	IP20
Ambient conditions	Operation	As per IEC/EN 60721-3-3
	Climatic conditions	Class 3K23
	Temperature	-5...50 °C
	Humidity	5...95 % rh
	Mechanical conditions	Class 3M11
	Transport / storage	As per IEC/EN 60721-3-2 /-3-1
	Climatic conditions	Class 2K12 / 1K22
	Temperature	-25...70 °C
	Humidity	5...95 % rh
	Mechanical conditions	Class 2M4
Standards, directives and approvals	Product standard	EN 60730-1
	Electromagnetic compatibility (Applications)	Automatic electrical controls for household and similar use For use in residential, commercial, light-industrial and industrial environments
	EU conformity (CE)	See EU declaration of conformity *)
	UL certification (US)	UL 916, http://ul.com/database
	RCM-conformity (EMC)	See RCM declaration of conformity*)
	EAC conformity	Eurasia conformity
Environmental compatibility	Product environmental declaration (contains data on RoHS compliance, materials composition, packaging, environmental benefit, disposal)	CM2E8177 *)
Color	Plug-in I/O module and terminal base top	2003 Ti-Grey
	Terminal base bottom	804 Black
Dimensions	Housing to DIN 43 880, see "Dimensions"	
Weight	Without / with packaging	246 / 268g

*) The documents can be downloaded from <http://siemens.com/bt/download>.

Connection diagrams (examples)

Terminal layout

I/O point	TXM1.6RL					
	(1)	(2)	(3)	(4)	(5)	(6)
Supply	1	7	13	20	26	32
N/O contact, bistable (fail-safe behavior can be parameterized)	2	8	14	21	27	33

Maintained contact

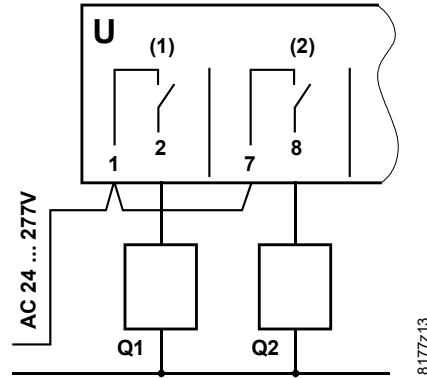

U Relay module bistable

Q1, Q2 Switched load

Mixed phases

permitted on adjacent I/O points of the module.

Restriction for UL916: I/O points 1...3 and 4...6 must have the same phase.

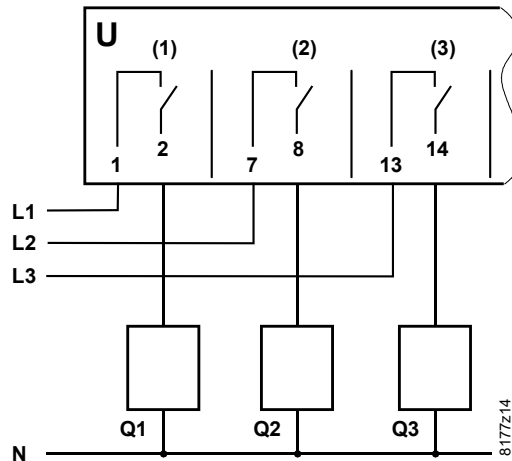

U Relay module bistable

Q1, Q2, Q3
Switched loads on 3 phases



Note!

With modules from Series D it is compulsory to feed AC 24 V to bus terminal "V~" (field supply) if there is a bus connection module. TXM1.6RL always monitors this supply.

Simatic: it is also admissible to connect DC 24 V.

When AC / DC 24 V returns after a failure, the module reports the state of every configured output to the bus master. This guarantees that BACnet clients and light switches correctly display the state of the outputs.

Dimensions

Dimensions in mm

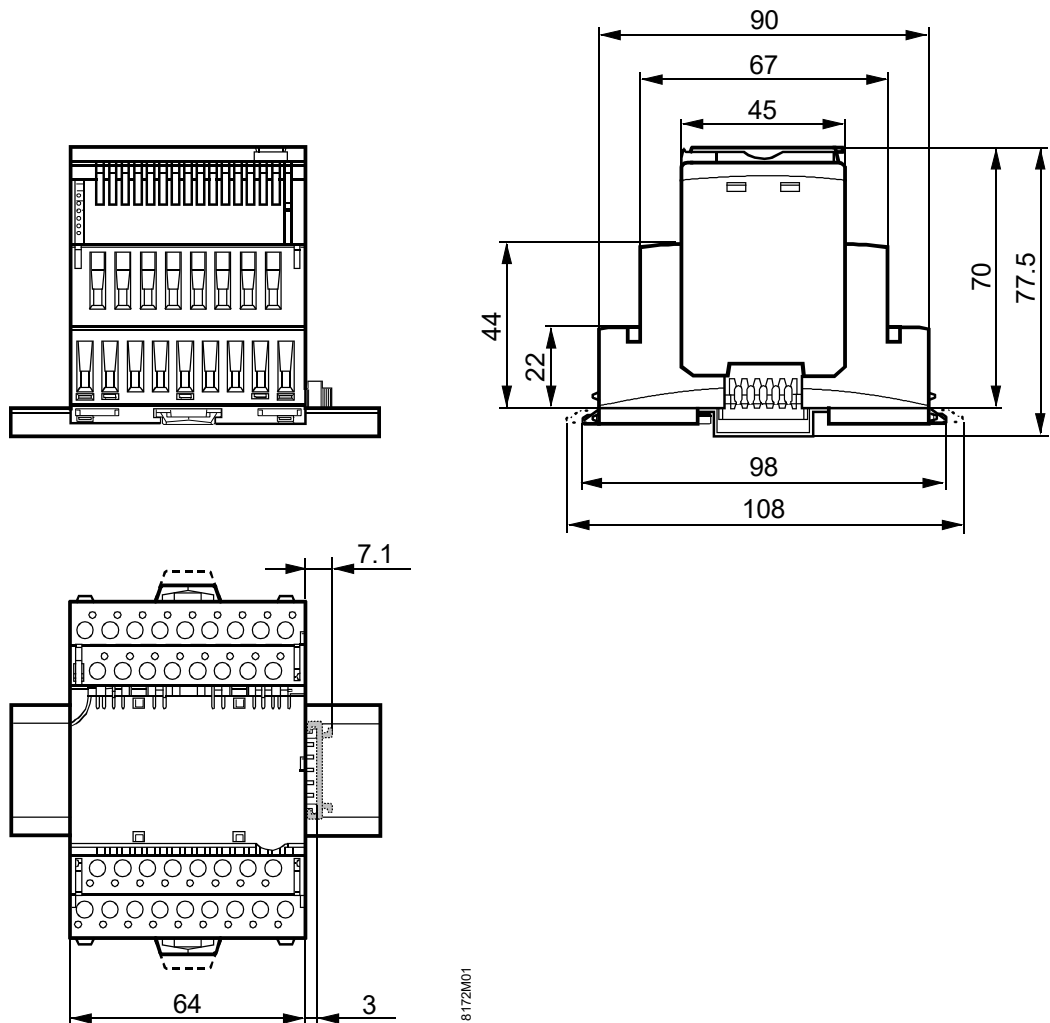

Published by:
Siemens Switzerland Ltd.
Smart Infrastructure
Global Headquarters
Theilerstrasse 1a
6300 Zug
Switzerland
Tel. +41 58-724 24 24
www.siemens.com/buildingtechnologies

© Siemens Switzerland Ltd 2010
Delivery and technical specifications subject to change