

ACVATIX™

Rotary actuator for ball valves KNX / PL-Link

G..B111.9E/KN



Rotary actuator 5 / 10 Nm with KNX communication for 6-port control ball valves and ball valves

- Nominal torque:
 - GDB111.9E/KN: 5 Nm
 - GLB111.9E/KN: 10 Nm
- Operating voltage: AC 24 V
- Supports KNX S-Mode and PL-Link
- For use with VWG4.. 6-port control ball valves and with 2-port and 3-port ball valves up to DN25 / DN50

Functions

Function	Description
Communication	<ul style="list-style-type: none"> • KNX-TP, galvanically separated • Max. 256 nodes per line (with repeaters) • Busload 5 mA
Functions	<ul style="list-style-type: none"> • Setpoint and actual value for actuator position 0...100 % • Operating mode "heating/cooling control" for 6-port control ball valve with 2 separate setpoints and actual values, or operating mode "position control" for 2-/3-port control ball valves • Override control with binary communication objects • - Setpoint monitoring and backup mode (can be turned off)

Type summary

Type	Stock no.	Operating voltage	Control signal	Power consumption	Running time	Manual override	Position feedback
GDB111.9E/KN	S55499-D203	AC 24 V	KNX-TP	1 VA / 0.5 W 3 VA / 2.5 W ¹⁾	150 s	Yes	Yes
GLB111.9E/KN	S55499-D207						

¹⁾ Actuator running

Ordering (example)

Type	Stock no.	Description	Quantity
GDB111.9E/KN	S55499-D203	Rotary actuator KNX for 6-port ball valve or control ball valves	1

Accessories

Type	Stock no.	Description
ALJ100	S55846-Z115	Temperature adapter for ball valves

Equipment combinations

6-port control ball valves PN16				GDB..9E/KN	GLB..9E/KN	
Medium: 5...90 °C		G..B	k _{vs} [m³/h]	DN	Δp _{max} [kPa]	Δp _{max} [kPa]
	VWG42.10..	G ½ B	0.25...1.95	10	200	—
	VWG41.20..	G 1 B	0.25...4.25	20		

2- and 3-port control ball valves PN40						GDB..9E/KN		GLB..9E/KN	
Internally threaded	Rp	Externally threaded	G..B	k_{vs} [m³/h]	DN	Δp_{max}	Δp_s	Δp_{max}	Δp_s
2-port control ball valves									
—	—	VAG61.15..	G 1 B	1...6.3	15	350	1400	—	—
VAI61.15..	Rp ½"	—	—	0.25...10					
VAI61.20..	Rp ¾"	VAG61.20..	G 1¼ B	4...10	20				
VAI61.25..	Rp 1"	VAG61.25..	G 1½ B	6.3...16	25	—	—	350	1000
VAI61.32..	Rp 1¼"	VAG61.32..	G 2 B	10...25	32				800
VAI61.40..	Rp 1½"	VAG61.40..	G 2¼ B	16...40	40				600
VAI61.50..	Rp 2"	VAG61.50..	G 2¾ B	25...63	50				
3-port control ball valves									
VBI61.15..	Rp ½"	VBG61.15..	G 1 B	1.6...6.3	15	350	—	—	—
VBI61.20..	Rp ¾"	VBG61.20..	G 1¼ B	4...6.3	20				
VBI61.25-10	Rp 1"	VBG61.25-10	G 1½ B	10	25				
VBI61.32-16	Rp 1¼"	VBG61.32-16	G 2 B	16	32	—	—	350	—
VBI61.40-25	Rp 1½"	VBG61.40-25	G 2¼ B	25	40				
—	—	VBG61.50-40	G 2¾ B	40	50				
VBI61.50..	Rp 2"	—	—	40...63					

Cf. "Product documentation [► 4]" for further information.

Controllers and room units	Type	Stock no.	Documentation
Room thermostat KNX	RDG160KN	S55770-T297	A6V10629627 (N3191)
Flush-mount room sensor KNX	AQR2532NNW <i>with</i> AQR2570NF <i>or</i> AQR2576NF	S55720-S136 S55720-S203 S55720-S207	A6V10389050 (N1411)
Room control unit	UP227/11	5WG1227-2AB11	A6V10387579

Software versions

G..B111.9E/KN series B are designed for using ETS device profiles v2.x. ETS device profiles v1.x is supported for backward compatibility reasons.

Series information	Series A	Series B
Production period	12/2015 - 01/2017	from 01/2017
ETS device profile v1.x	supported	supported
ETS device profile v2.x	not supported	supported



The Software-Tools ACS931 / 941 and the handheld tool AST20 are **not** supported by the GDB111.9E/KN and GLB111.9E/KN.

Title	Topic	Document ID
KNX bus communications	Basic documentation: Communication via the KNX bus, device range Synco 700, Synco living, RXB/RXL, RDG, RDF, RDU	P3127
Mounting instructions Rotary-type actuator G..B..9E..	Mounting instructions (incl. G..B111.9E/KN)	M4657
6-port compact control ball valve	Datasheet: Technical information on VWG42.10.. (DN 10)	A6V14034341
6-port control ball valve	Datasheet: Technical information on VWG41.20.. (DN 20)	A6V10564480
2-port- and 3-port control ball valves, PN 40, with internally threaded connection	Datasheet: Technical information on VAI61.. und VBI61..	N4211
2-port- and 3-port control ball valves, PN 40, with externally threaded connection	Datasheet: Technical information on VAG61.. and VBG61..	N4212
2-port shutoff valves and 3-port changeover ball valves, PN 40, with internally threaded connection	Datasheet: Technical information on VAI60.., VBI60..L and VBI60..T	N4213
2-port shutoff valves and 3-port changeover ball valves, PN 40, with externally threaded connection	Datasheet: Technical information on VAG60.., VBG60..L and VBG60..T	N4214

How to obtain documentation and product-related software

Related documents such as the environmental declarations, declarations of conformity, etc., can be downloaded from the following Internet address:

www.siemens.com/bt/download

The ETS device profile can be downloaded from the following Internet address:

<http://siemens.com/hvac-td>

HMI (Human-Machine Interface)

Push-button operation

Activity	Push-button operation	Feedback
Enter/leave addressing mode	Press button briefly (<1 s)	LED turns red (addressing mode on) or turns off (addressing mode off)
Reset to factory settings	Press and hold button >20 s	LED flashes orange until device restarts
PL-Link connection test ¹⁾	Press and hold button 2...20 s	LED flashes orange 1 x

¹⁾ Function or part of the function available in PL-Link operation only.

LED colors and patterns

Color	Pattern	Description	
Off	—	Fault-free operation or device not powered	
Green	steady	Connection test successful ¹⁾	
Orange	flashing	0.1 s on / 0.1 s off	Factory reset in progress
		0.25 s on / 1.75 s off	When a connection test was triggered: wait ¹⁾
Red	steady	Device is in programming/addressing mode	
	flashing	0.5 s on / 2 s off	Internal error: power reset necessary
		1 s on / 1 s off	When a connection test was triggered: test failed ¹⁾

¹⁾ Function or part of the function available in PL-Link operation only.

Addressing and bus test with push-button

The rotary actuators can be set into addressing/programming mode by push-button:

- ◆ Press button briefly (<1 s).
 - ⇒ KNX bus wiring OK → LED turns **red** until addressing/programming is finished.
 - ⇒ KNX bus wiring **not** OK → LED stays off.

Reset with push-button

The rotary actuators can be reset by push-button:

- ◆ Press and hold button >20 s.
 - ⇒ LED flashes **orange**.
 - ⇒ Device restarts.
- ⇒ All parameters are reset to the default values.

Commissioning and parameterization

The following operating modes are available:

- *Heating/cooling control*: The actuator uses 2 separate setpoints for heating and cooling each with a range 0...100 %.
- *Position control*: The actuator is controlled with a 0...100 % positions setpoint.

Operating mode "Heating/cooling control"

When using "heating/cooling control", the parameters as listed below are available. Parameter sets for 6-port control ball valves DN 10 and DN 20 can be selected in the ETS. Details on the characteristic curves of these valves can be found in the datasheets A6V14034341 (VWG42.10..) and A6V10564480 (VWG41.20..).

Note that the valve angle [°] moves counter-clockwise, whereas the actuator position [%] moves clockwise. Therefore valve angle 0° is achieved by an actuator position of 100 % etc. One of the two setpoints (heating or cooling) needs to be "0 %" in order for the actuator to be able to move. If neither setpoint is equal to "0 %", the actuator does not move until the setpoint conflict is resolved.

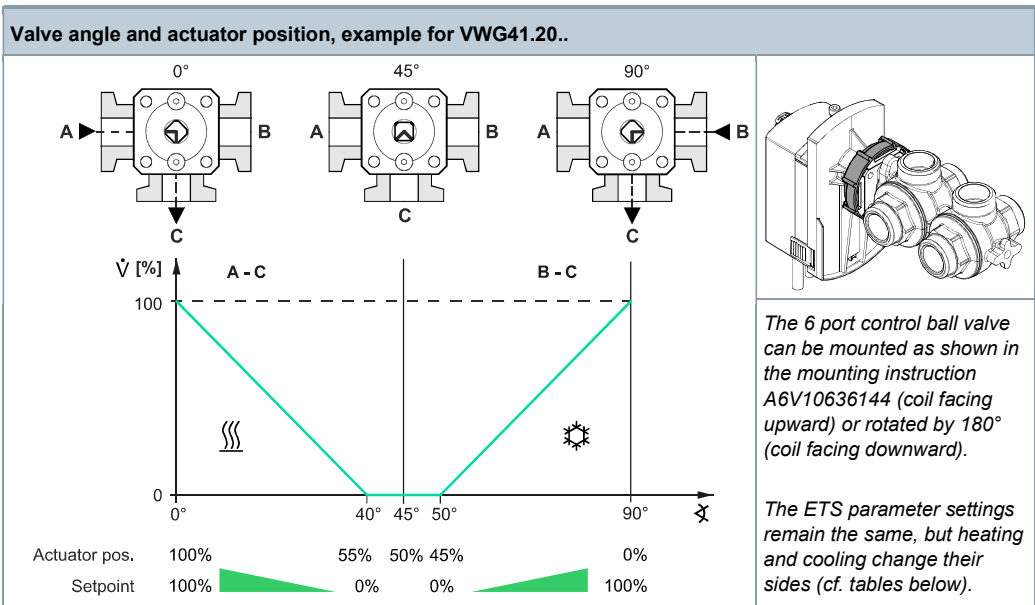

Parameters for standard piping of heating/cooling:

Parameter	VWG42.10..	VWG41.20..	
	Actuator position		
Max. position heating	100 %	100 %	
Min. position heating	55 %	55 %	
Closed position	50 %	50 %	
Min. position cooling	45 %	45 %	
Max. position cooling	0 %	0 %	

By parameter inversion, heating and cooling are swapped:

Parameter	VWG42.10..	VWG41.20..	
	Actuator position		
Max. position heating	0 %	0 %	
Min. position heating	45 %	45 %	
Closed position	50 %	50 %	
Min. position cooling	55 %	55 %	
Max. position cooling	100 %	100 %	

Operating mode "Position control"

Parameters available in "Position control":			
Parameter	Range	Description	Factory setting
Opening direction	CW (R) / CCW (L)	Opening direction of the actuator	CW (R)
Max. position	0...100 %	Setting for the upper position limit	100 %
Min. position	0...100 %	Setting for the lower position limit	0 %

Parameterization of the KNX bus integration

The following parameters are usually checked and set by the systems integrator to achieve the right level of bus traffic generated by the actuator or to define the behavior in case of communication interruption. Parameters in the group "Advanced" can be left unchanged unless a special configuration is required.

Parameter group "Standard"			
Parameter	Range	Description	Factory setting
Backup timeout	0...60 min <i>0 min = disabled</i>	Time interval to detect communication interruption. If disabled, the actuator controls to the last received setpoint until a new valid setpoint is received.	30 min
Backup mode	Backup position / Keep last position	Actuator behavior when the communication timeout has been exceeded (no setpoint received within the defined time interval). <ul style="list-style-type: none">• <i>Backup position</i>: Actuator drives to defined position• <i>Keep last position</i>: Actuator keeps position	Backup position
Backup value	0...100 %	Position the actuator drives to in case of communication interruption.	50 %

Parameter group "Advanced"			
Parameter	Range	Description	Factory setting
Hysteresis (COV) actuator position ¹⁾	1...20 %	Threshold for the actuator position. COV below this value are not sent over the bus.	1 %
Min. repetition time actuator position	10...900 s	Minimum waiting time until a COV above the hysteresis threshold is sent over the bus.	10 s
Override position 1 ²⁾	0...100 %	Position to which the actuator drives if the associated group object is triggered (override priority).	50 %
Override position 2 ²⁾	0...100 %		50 %

¹⁾ COV = Change of value

²⁾ Override position 1 has priority over Override position 2

Safety

⚠ CAUTION



National safety regulations

Failure to comply with national safety regulations may result in personal injury and property damage.

- Observe national provisions and comply with the appropriate safety regulations.

Engineering

GDB..9E.. actuators may only be used at medium temperatures of $> 0\text{ }^{\circ}\text{C}$.

If condensation occurs at the mounting site, the use of the temperature adapter ALJ100 is recommended in order to protect the actuator. If the medium temperature is $\leq 0\text{ }^{\circ}\text{C}$, the adapter shaft must be greased with silicon grease.

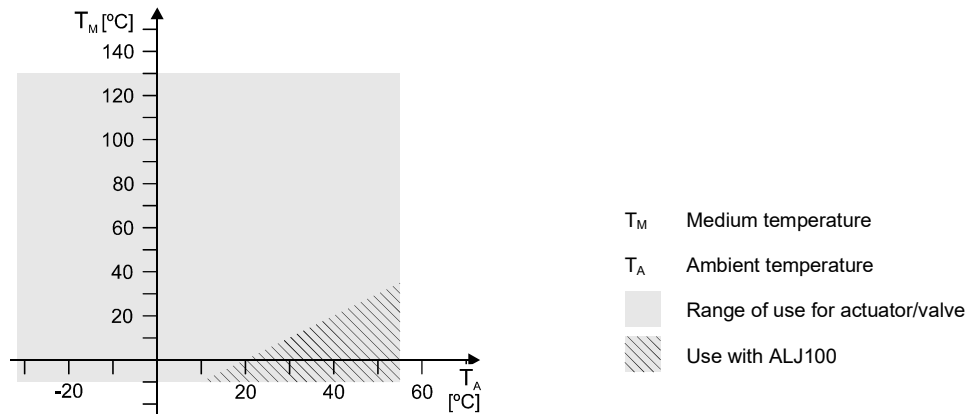

Mounting

IP54 in the following mounting positions

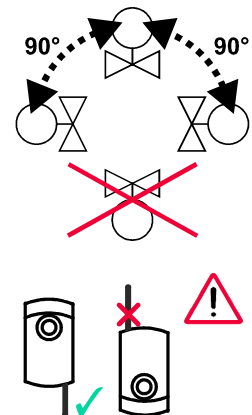
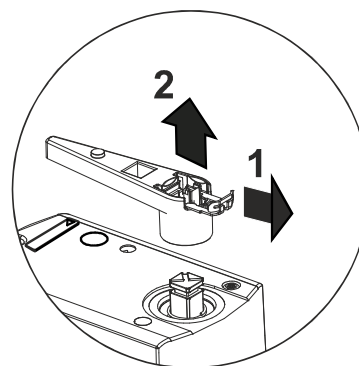
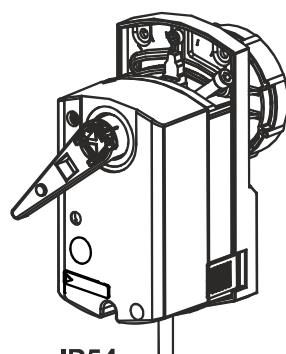

Maintenance

The rotary actuators G..B111.9E/KN are maintenance-free.

Disconnect the electrical connections from the terminals if you have to work at the device.

Disposal



This symbol or any other national label indicate that the product, its packaging, and, where applicable, any batteries may not be disposed of as domestic waste. Delete all personal data and dispose of the item(s) at separate collection and recycling facilities in accordance with local and national legislation.

For additional details, refer to [Siemens information on disposal](#).

Warranty

The application-specific technical data is guaranteed only in combination with the Siemens products listed in the 'Device combinations' section. If third-party products are used, any guarantee provided by Siemens will be invalidated.

KNX Group objects

No.	Name in ETS	Object function	Flags					Data point type KNX			Range	
			C	R	W	T	U	ID	DPT_Name	Format		Unit
1	Fault information	Transmit	1	1	0	1	0	219.001	_AlarmInfo	6 Byte	—	[0...255] = Log No. [0...2] = Alarm priority [0...14] = Application area [0...4] = Error class [0...7] = Attributes [0...7] = Alarm status
2	Fault state	Transmit	1	1	0	1	0	1.005	_Alarm	1 bit	—	0 = No alarm 1 = Alarm
3	Fault transmission	Receive	1	0	1	0	1	1.003	_Enable	1 bit	—	0 = Disable 1 = Enable
4	Setpoint position / Setpoint pos. heating ¹⁾	Receive	1	1	1	0	1	5.001	_Scaling	1 Byte	[%]	0...100 %
5	Actual position / Actual pos. heating ¹⁾	Transmit	1	1	0	1	0	5.001	_Scaling	1 Byte	[%]	0...100 %
6	Setpoint pos. cooling ¹⁾	Receive	1	1	1	0	1	5.001	_Scaling	1 Byte	[%]	0...100 %
7	Actual position cooling ¹⁾	Transmit	1	1	0	1	0	5.001	_Scaling	1 Byte	[%]	0...100 %
8	Fault	Transmit	1	1	0	1	0	1.005	_Alarm	1 bit	—	0 = No alarm 1 = Alarm
9	Override position 1	Receive	1	1	1	0	1	1.003	_Enable	1 bit	—	0 = Disable 1 = Enable
10	Override position 2	Receive	1	1	1	0	1	1.003	_Enable	1 bit	—	0 = Disable 1 = Enable

¹⁾ For operating mode "heating/cooling control"

Group objects description

1	Fault information	If the group object #3 "fault transmission" is set to "on", the following faults can be transmitted if they occur. In that case, group object #2 value changes to "alarm".			
		Fault	Group obj. #1	Description	Resolution
		Device jammed	XX 00 0A 03 0C 05	Target position cannot be reached due to blockage.	<ul style="list-style-type: none"> Remove blockage (visual inspection required). Invert opening direction, if it is set wrongly. Switch on adaptive positioning, if mechanical limits are intended.
		Backup mode entered	XX 01 01 02 0C 05	Actuator is in backup mode (cf. respective parameter setting).	<ul style="list-style-type: none"> Actuator leaves backup mode when receiving a setpoint.
	Operating hours notification	XX 01 0A 04 0C 05	Appears after a cumulated motor running time of 365 days.	<ul style="list-style-type: none"> Check device status and control loop sensitivity. 	
2	Fault state	Indicates whether the actuator is in fault state. If yes, read out group object #1 for more details.			
3	Fault transmission	Enabling/ disabling the fault transmission. Fault transmission is disabled by default; therefore no faults are transmitted from the actuator over the KNX bus.			
4	Setpoint position / Setpoint pos. heating	Setpoint 0...100% for valve position, depending on the operating mode.			
5	Actual position / Actual pos. heating	Actual value 0...100% for valve position, depending on the operating mode.			
6	Setpoint pos. cooling	Setpoint 0...100% for the valve position; available in operating mode "heating/cooling control".			
7	Actual pos. cooling	Actual value 0...100% for the valve position; available in operating mode "heating/cooling control".			
8	Fault	Same function as group object #2 (available for compatibility reasons).			
9	Override position 1	When the object is triggered, the actuator drives to the override position 1 defined by the respective ETS parameter.			
10	Override position 2	When the object is triggered, the actuator drives to the override position 2 defined by the respective ETS parameter.			

Technical data

Power supply		
Operating voltage		AC 24 V \pm 20 % (SELV) <i>or</i> AC 24 V, class 2 (US)
Frequency		50/60 Hz
Power consumption at 50 Hz	Actuator runs	3 VA / 2.5 W
	Actuator holds	1 VA / 0.5 W

Function data			
Positioning time (for nominal rotation angle 90°)	at 50 Hz	150 s	
	at 60 Hz	120 s	
Torque	nominal	GDB..	5 Nm
		GDB	10 Nm
	maximum	GLB	<7 Nm
		GLB..	<14 Nm
Rotation angle	nominal	90°	
	maximum	95° \pm 2°	
Direction of rotation	adjustable over bus (operating mode "position control")	Clockwise (CW) / Counter-clockwise (CCW)	
Permissible medium temperature in the valve	in combination with GDB.. actuators	0...120 °C	

Connection cables		
Cable length		0,9 m
No. of cores / cross- sectional area	power supply (black)	2 x 0.75 mm ²
	communication (green)	2 x 0.75 mm ²

Communication		
Communication protocol	Connection type	KNX-TP (electrically isolated)
	Bus load	5 mA

Degree of protection	
Degree of protection	Degree of protection acc. to EN 60529 (see notes in "Mounting [► 8]")
Safety class	Safety class acc. to EN 60730

Environmental conditions		
Operation		IEC 60721-3-3
	Climatic conditions	Class 3K5
	Mounting location	Indoors
	Temperature general	-32...55 °C
	Humidity (non-condensing)	5...95 % r. h.
Transport		IEC 60721-3-2
	Climatic conditions	Class 2K3
	Temperature	-25...70 °C
	Humidity (non-condensing)	5...95 % r. h.
Storage		IEC 60721-3-1
	Climatic conditions	Class 1K3
	Temperature	-5...45 °C
	Humidity (non-condensing)	5...95 % r. h.

Directives and standards		
Product family standard		EN 50491-2, EN 50491-3, EN 50491-5 General requirements for Home and Building Electronic Systems (HBES) and Building Automation and Control Systems (BACS)
Electromagnetic compatibility (Application)		For residential, commercial and industrial environments
EU Conformity (CE)		A5W00003842 ¹⁾
UK Conformity (UKCA)		A5W00198029A ¹⁾
RCM Conformity		A5W00003843 ¹⁾
UL, cUL Approbation	AC 24 V	UL 873 http://ul.com/database

Environmental compatibility
The product environmental declaration A6V10209938 ¹⁾ contains data on environmentally compatible product design and assessments (RoHS compliance, materials composition, packaging, environmental benefit, disposal).

Dimensions and weight		
Dimensions W x H x D		74 x 143 x 112.5 mm (cf. "Dimensions [► 13]")
Weight	without packaging	0.6 kg

¹⁾ The documents can be downloaded from <http://siemens.com/bt/download>.

Diagram

Internal diagram / connection cables

The KNX rotary actuator is supplied with 2 prewired power supply and communication cables.

	Core desig.	Core color	Terminal code	Description	
	Cable 1: Power / black sheathing				
	1	red	RD	G	System voltage AC 24 V
	2	black	BK	G0	System neutral AC 24 V
	Cable 2: KNX / green sheathing				
	1	red	RD	CE+	KNX CE+
	2	black	BK	CE-	KNX CE-

NOTICE



The operating voltage at terminals G and G0 must comply with the requirements under SELV or PELV.

Safety transformers with twofold insulation as per EN 61558 required; they must be designed to be on 100 % of the time.

Dimensions

Actuators G..B111.9E/KN

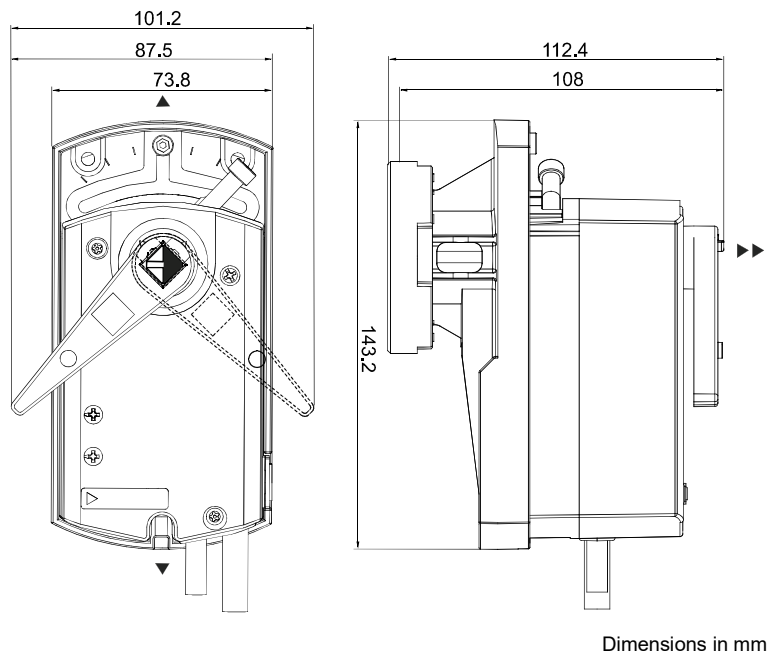

Temperature adapter ALJ100 (optional)

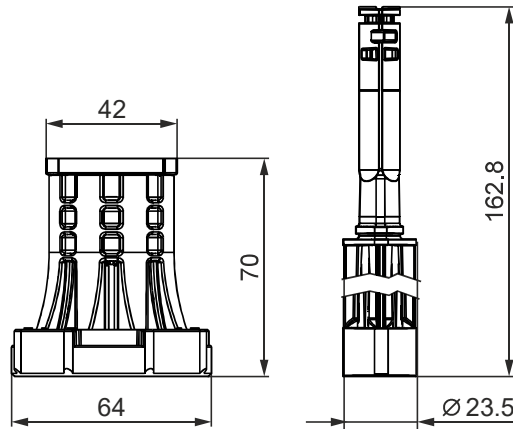

Dimensions in mm

Revision numbers

Type	Stock no.	Valid from rev. no.
GDB111.9E/KN	S55499-D203	..A
GLB111.9E/KN	S55499-D207	..A

Issued by
Siemens Switzerland Ltd
Smart Infrastructure
Global Headquarters
Theilerstrasse 1a
CH-6300 Zug
+41 58 724 2424
www.siemens.com/buildingtechnologies

© Siemens Switzerland Ltd, 2015 - 2024
Technical specifications and availability subject to change without notice.

Document ID A6V10725318_en--_q
Edition 2024-07-09