

ACVATIX™

Rotary actuators for ball valves

GDB..9E..





Electromotive rotary actuators for open-close, three-position or modulating control. Used in heating, ventilation and air conditioning plants.

- For 2-port and 3-port control ball valves, internally threaded connections (VAI61.. and VBI61..) or externally threaded connections (VAG61.. and VBG61..), DN15 to DN25
- For open/close ball valves 2-port and changeover ball valves 3-port, internally threaded connections (VAI60.. and VBI60..) or externally threaded connections (VAG60.. and VBG60..), DN15 to DN25
- Nominal torque 5 Nm
- Operating voltage GDB141.9E and GDB161.9E AC 24 V ~ / DC 24...48 V =
- Operating voltage GDB341.9E AC 100...240 V ~
- Operating voltage GDB161.9E/MO AC 24 V ~ / DC 24 V =
- Positioning signal DC 0/2...10 V =
- GDB161.9E/MO: RS-485 for Modbus RTU communication
- Pre-wired with 0.9 m long connection cables

Features

- Brushless, robust DC motors ensure reliable operation regardless of load.
- The rotary actuators do not require an end position switch, are overload proof, and remain in place upon reaching the end stop.
- The gears are maintenance free and low noise.
- Suitable for use with modulating controllers (DC 0/2...10 V), open-close or three-position controllers.
- We recommend a minimum pulse length of 500 ms on rotary actuators operated with 3-point control to ensure continuous and accurate operation.

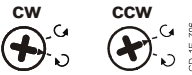
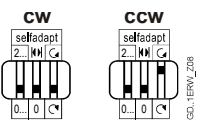
Functions

GDB..	AC 24 V ~ / DC 24...48 V –	141.9E	161.9E	–
	AC 24 V ~ / DC 24 V –	–	–	161.9E/MO
	AC 100...240 V ~	341.9E	–	–
Control type	Open-close / three-position	Modulating control (0/2... 10 V)	Modbus RTU	
Rotary direction	<p>Clockwise (cw) or counter-clockwise (ccw) direction depends on the type of control. With no power applied, the actuator remains in the respective position. ... on the setting of the rotary direction DIL switch</p> 	<p>... on the setting of the rotary direction DIL switch</p>  <p>... on the positioning signal</p> <p>The actuator remains in the achieved position: ... if the control signal is maintained at a constant value ... for loss of operating voltage.</p>	– –	
Combination with 2-port or 3-port control ball valves	NC (normally closed) ball valve	NC (normally closed) ball valve	–	–
	Basic setting: Y1: Opening Y2: Closing		Basic setting: Y1: Opening Y2: Closing	–
	NO (normally open) ball valve	NO (normally open) ball valve	–	–
	Basic setting: Y1: Closing Y2: Opening		Basic setting: Y1: Closing Y2: Opening	–
Position indication: Mechanical	Rotary angle position indication by a position indicator/hand lever.			
Position indication: Electrical		Output voltage U = DC 0/2...10 V is generated proportional to the rotary angle. U depends on the rotary direction of the DIL switch setting.		
Self-adaptation of linear span		When self-adaptation is active, the actuator automatically determines the mechanical end positions of the linear span.		
Manual adjustment	The rotary actuator can be manually adjusted by pressing the gear train disengagement button.			

	AC 24 V ~ / DC 24...48 V =	141.9E	161.9E	—
GDB..	AC 24 V ~ / DC 24 V =	—	—	161.9E/MO
	AC 100...240 V ~	341.9E	—	—
Rotary angle limitation	The rotary angle of the shaft adapter can be limited mechanically with a set screw.			
Modbus RTU (RS-485), not galvanically isolated				Setpoint 0...100 % valve position Actual value 0...100 % for valve position Override control Open / Close / Min / Max / Stop Setpoint monitoring and backup mode

Technical design

Housing

The housing consists essentially of flame retardant, non-brominated, non-chlorinated glass fiber reinforced plastic.

Type summary

Type	Stock no.	Control	Operating voltage	Position indicator U = DC 0...10 V =	Self-adaption of rotational angle range	Aux. switches	Rotary direction switch
GDB141.9E	S55499-D200	Open-close or three-position	AC 24 V ~ / DC 24...48 V =	—	—	—	yes
GDB341.9E	S55499-D201		AC 100...240 V ~				
GDB161.9E	S55499-D275	Modulating	AC 24 V ~ / DC 24...48 V =	yes	yes	—	
GDB161.9E/MO	S55499-D682	Modbus RTU	AC 24 V ~ / DC 24 V =				

Accessories / Spare parts

Spare parts

Individual spare parts are not available. Components of the accessory kit ASK77.3¹⁾, available as an accessory, can however be used for spare parts.

Description	Components
ASK77.3 Accessory Kit BV for GxBxx1.9E	Mounting bracket (base plate) Axle with sleeve and spring Manual lever with locking clip

¹⁾ Can also be used as rotary actuator for ball valves together with the actuator for air dampers G..B.1E.

Accessories

Type	Stock no.	Description
ALJ100	S55846-Z115	Temperature adapter for ball valves

Equipment combinations

GDB..9E.. and VA..61.. 2-port control ball valves

Control ball valves with:						GDB..9E..	
internal threads ¹⁾	Rp	external threads ²⁾	G..B	k _{vs} [m ³ /h]	DN	Δp _{max}	Δp _s
–	–	VAG61.15..	G 1 B	1...6.3	15	350	1400
VAI61.15..	Rp ½"	–	–	0.25...10	15		
VAI61.20..	Rp ¾"	VAG61.20..	G 1 ¼ B	4...10	20		
VAI61.25..	Rp 1"	VAG61.25..	G 1 ½ B	6.3...16	25		

GDB.. 9E.. and VB..61.. 3-port control ball valves

Control ball valves with:						GDB..9E..	
internal threads ¹⁾	Rp	external threads ²⁾	G..B	k _{vs} [m ³ /h]	DN	Δp _{max}	Δp _s
VBI61.15..	Rp ½"	VBG61.15..	G 1 B	1.6...6.3	15	350	–
VBI61.20..	Rp ¾"	VBG61.20..	G 1 ¼ B	4...6.3	20		
VBI61.25-10	Rp 1"	VBG61.25-10	G 1 ½ B	10	25		

1) Data sheet N4211

2) Data sheet N4212

GDB.. 9E.. and VA..60.. open/close ball valves 2-port and VB..60.. changeover ball valves 3-port

Ball valves with:						GDB..9E..	
internal threads ³⁾	Rp	external threads ⁴⁾	G..B	k _{vs} [m ³ /h]	DN	Δp _{max}	Δp _s
–	–	VAG60.15-9	G 1 B	9	15	350	1400
VAI60.15-15	Rp ½"	–	–	15	15		
–	–	VAG60.20-17	G 1 ¼ B	17	20		
VAI60.20-22	Rp 1"	–	–	22	20		
VAI60.25-22	Rp 1"	VAG60.25-22	G 1 ½ B	22	25		
VBI60.15-5L	Rp ½"	VBG60.15-5L	G 1 B	5	15	350	–
–	–	VBG60.20-8L	G 1 ¼ B	8	20		
VBI60.20-9L	Rp 1"	–	–	9	20		
VBI60.25-9L	Rp 1"	VBG60.25-9L	G 1 ½ B	9	25		
–	–	VBG60.15-8T	G 1 B	8	15	350	–
VBI60.15-12T	Rp ½"	–	–	12	15		
–	–	VBG60.20-13T	G 1 ¼ B	13	20		
VBI60.20-16T	Rp 1"	–	–	16	20		
–	–	VBG60.25-13T	G 1 ½ B	13	25		
VBI60.25-16T	Rp 1"	–	–	16	25		

3) Data sheet N4213

4) Data sheet N4214

Topic	Title	Document ID
Data sheet	Rotary actuators for ball valves GDB..9E..	A6V10636150
Data sheet	Rotary actuators for ball valves G..161.9E/MO, Modbus communication profiles	A6V12513940
Mounting instructions	Rotary-type actuator GDB..9E..	A6V10636144
Mounting instructions	Ball valve VAI61.. / VBI61..	M4211
Mounting instructions	Ball valve VAG61.. / VBG61..	M4212
Mounting instructions	VAI60.. / VBI60..L / VBI60..T	M4213
Mounting instructions	VAG60.. / VBG60..L / VBG60..T	M4214

Related documents such as environmental declarations, CE declarations, etc., can be downloaded at the following Internet address: <http://siemens.com/bt/download>

Notes

Safety

	<p>⚠ Caution</p>
	<p>National safety regulations</p> <p>Failure to comply with national safety regulations may result in personal injury and property damage.</p> <ul style="list-style-type: none"> • Observe national provisions and comply with the appropriate safety regulations. • Use only properly trained technicians for mounting, commissioning, and servicing.



Mounting

Both ball valve and rotary actuator can easily be assembled at the mounting location. Neither special tools nor adjustments are required.

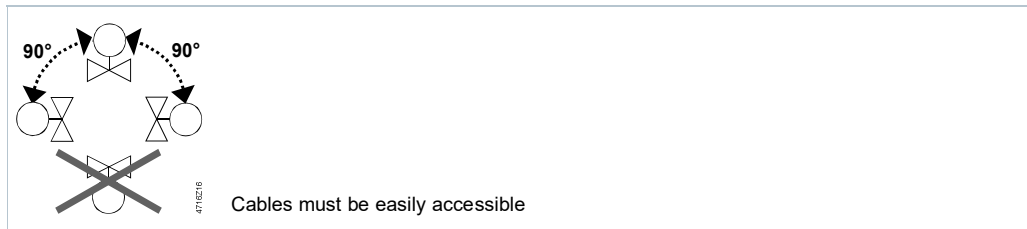
Orientation

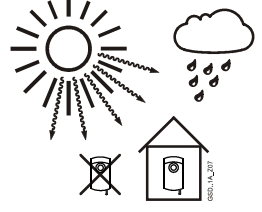
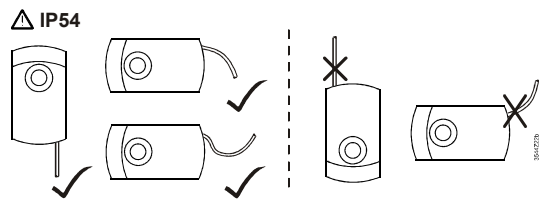

Protection against weather, humidity and dirt

	<p>⚠ IP54</p> 	
<p>Protection against direct sunlight and rain</p>	<p>Correct mounting position and cable connection</p>	<p>Protection only with closed cover!</p>

Installation



⚠ WARNING

No internal line protection for supply lines to external consumers

Risk of fire and injury due to short-circuits

- Adapt the line diameters as per local regulations to the rated value of the installed fuse.

Engineering

GDB..9E.. actuators may only be used at medium temperatures $> 0\text{ }^{\circ}\text{C}$.

If condensation occurs at the mounting site, the use of the temperature adapter ALJ100 is recommended in order to protect the actuator. If the medium temperature is $\leq 0\text{ }^{\circ}\text{C}$, the adapter shaft must be greased with silicon grease.

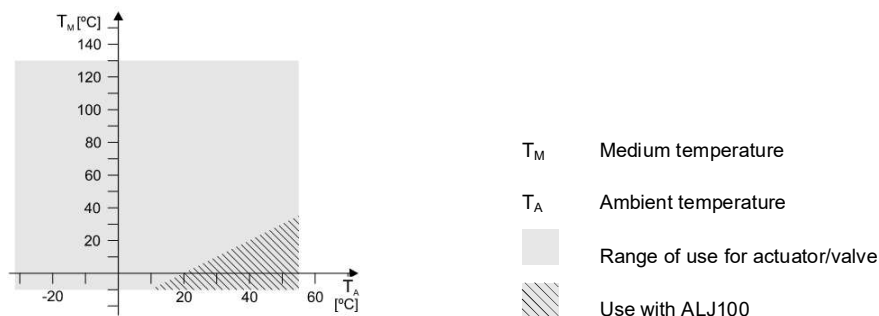

GDB161.9E/MO

The Modbus converter is designed for analog control at 0...10 V.

Commissioning

When commissioning the system, check wiring and the functions of the rotary actuator.

Manual adjustment

The rotary actuator can be manually adjusted into any position between 0° and 90° by pushing the gear train disengagement slider.

If a control signal from the controller is present, this will take priority in determining the position after the slider is released.

For manual adjustment: Power off!

Maintenance

The actuators GDB..9E.. are maintenance-free.

Disposal



The device is considered electrical and electronic equipment for disposal in terms of the applicable European Directive and may not be disposed of as domestic garbage.

- Dispose of the device through channels provided for this purpose.
- Comply with all local and currently applicable laws and regulations.

Power supply GDB1..9E..		
Operating voltage (SELV/PELV) / Frequency	GDB141.9E GDB161.9E	AC 24 V ~ ±20 % (19.2...28.8 V ~) / 50/60 Hz DC 24...48 V = ±20 % (19.2...57.6 V =) ¹⁾
	GDB161.9E/MO	AC 24 V ~ ±20 % (19.2...28.8 V ~) / 50/60 Hz DC 24...48 V = ±20 % (19.2...28.8 V =)
Power consumption running	GDB141.9E	2 VA / 1 W
	GDB161.9E	2.1 VA / 1.2 W
	GDB161.9E/MO	2.6 VA / 1.7 W
Power consumption holding	GDB141.9E	0.5 W
	GDB161.9E	0.7 W
	GDB161.9E/MO	1.2 W

Power supply GDB341.9E	
Operating voltage / Frequency	AC 100...240 V ~ ±10 % (90...264 V ~) / 50/60 Hz
Power consumption running	5 VA / 1.6 W
Power consumption holding	0.9 W

Function data	
Nominal torque	5 Nm
Maximum torque (blocked)	10 Nm
Minimum holding torque	5 Nm
Nominal rotary angle (with position indication)	90°
Maximum rotary angle (mechanic limitation)	95° ± 2°
Runtime for 90° rotary angle	150 s
Permissible medium temperature in the valve in combination with GDB.. actuators	0...120 °C
Actuator sound power level	28 dB(A)

Inputs		
Positioning signal for GDB141.9E	Operating voltage	(wires 1-6/G-Y1)
	AC 24 V ~ / DC 24...48 V =	(wires 1-7/G-Y2)
		clockwise counterclockwise
Positioning signal for GDB341.9E	Operating voltage	(wires 4-6/N-Y1)
	AC 100...240 V ~	(wires 4-7/N-Y2)
		clockwise counterclockwise
Positioning signal for GDB161.9E..	Input voltage	(wires 8-2/Y-G0)
	Current consumption	
	Input resistance	
Max. permissible input voltage		DC 0/2...10 V =
Protected against faulty wiring		0.1 mA
Hysteresis		>100 kΩ
		DC 35 V = limited to DC 10 V =
		max. AC 24 V ~ / DC 24...48 V =
		60 mV

Communication GDB161.9E/MO		
Communication protocol		
Modbus RTU		RS-485, not galvanically isolated
Number of nodes		Max. 32
Address range		1... 245 / 255
	Factory setting	255
Transmission formats		1-8-E-1 / 1-8-O-1 / 1-8-N-1 / 1-8-N-2
	Factory setting	1-8-E-1
Baud rates (kbaud)		Auto / 9.6 / 19.2 / 38.4 / 57.6 / 76.8 / 115.2
	Factory setting	Auto
Bus termination		120 Ω electronically switchable
	Factory setting	Off

Outputs	
Position indicator (GDB161.9E..) Output signal (wires 9-2/U-G0) Output voltage U Max. output current Protected against faulty wiring	DC 0...10 V \approx DC \pm 1 mA max. AC 24 V \sim / DC 24...48 V \approx
Connection cables	
Cable length	0.9 m
Cross section of prewired connection cables	0.75 mm ²
Permissible length for signal lines	300 m
Degree of protection	
Insulation class AC 24 V \sim / DC 24...48 V \approx , feedback potentiometer AC 100...240 V \sim , auxiliary switches	As per EN 60730 III II
Housing protection	IP 54 as per EN 60529
Environmental conditions	
Operation Climatic conditions Mounting location Temperature extended Humidity (non-condensing)	IEC 60721-3-3 Class 3K5 interior, weather-protected -32...+55 °C <95 % r.F.
Transport Climatic conditions Temperature extended Humidity (non-condensing)	IEC 60721-3-2 Class 3K5 / Class 2K3 -32...+70 °C <95 % r.F.
Storage Climatic conditions Temperature extended Humidity (non-condensing)	IEC 60721-3-1 Class 1K3 -32...+50 °C <95 % r.F.
Mechanical conditions	Class 2M2
Standards, directives and approvals	
Product standard	EN 60730 Part 2-14 / Particular requirements for electric actuators
Electromagnetic compatibility (Applications)	For use in residential, commercial, light-industrial and industrial environments
EU Conformity (CE)	A5W00003842 ²⁾
UK Conformity (UKCA)	A5W00198029A ²⁾
RCM Conformity	A5W00003843 ²⁾
EAC Conformity	Eurasian conformity
UL	UL as per UL 60730 http://ul.com/database cUL as per CSA-C22.2 No. 24-93
Environmental compatibility	
The product environmental declaration A5W00026068 ²⁾ contains data on environmentally compatible product design and assessments (RoHS compliance, materials composition, packaging, environmental benefit, disposal).	
Dimensions	
Actuator W x H x D	see „Dimensions“, page 12
Weight	
Without packaging	0.69 kg
External Modbus converter	0.15 kg

¹⁾ cUL: Permitted only to DC 30 V \approx

²⁾ The documents can be downloaded from <http://siemens.com/bt/download>.

Internal Diagrams

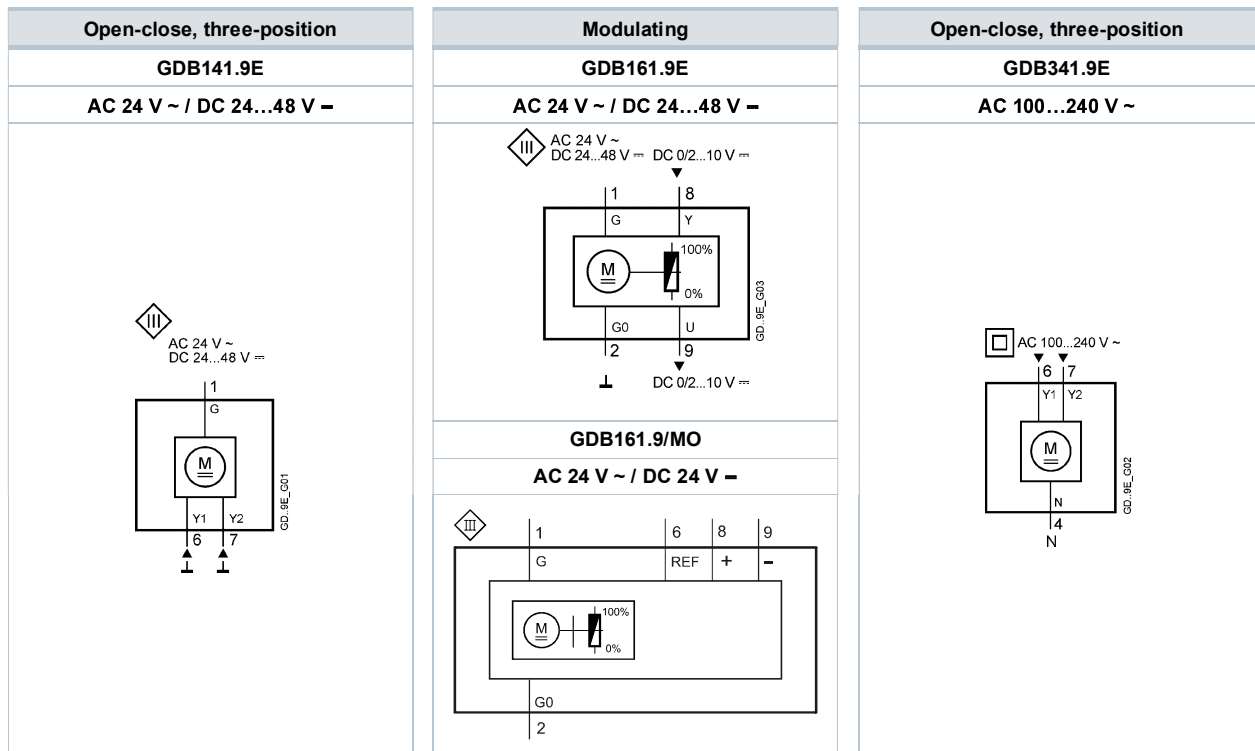

Connection diagrams

GDB1..9E (AC 24 V ~ / DC 24...48 V –)

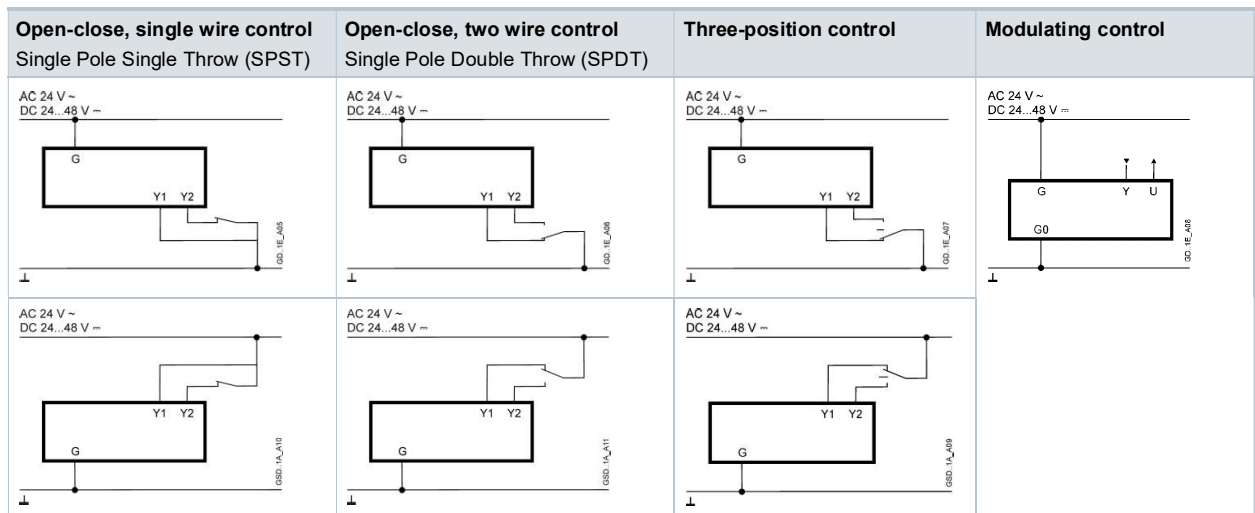

GDB161.9E/MO (AC 24 V ~ / DC 24 V =)

Modbus (AC 24 V ~ / DC 24 V =)

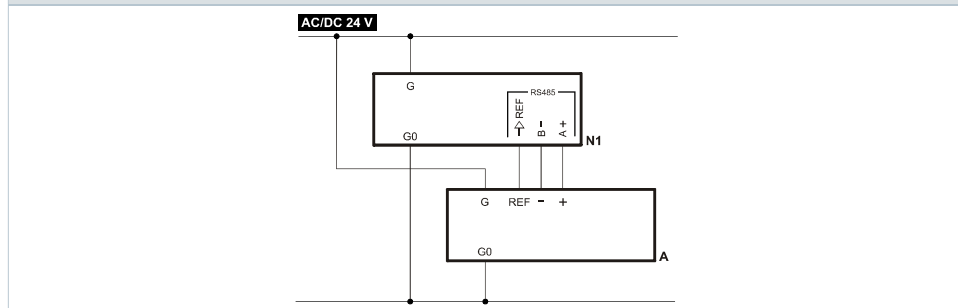

GDB341.9E (AC 100...240 V ~)

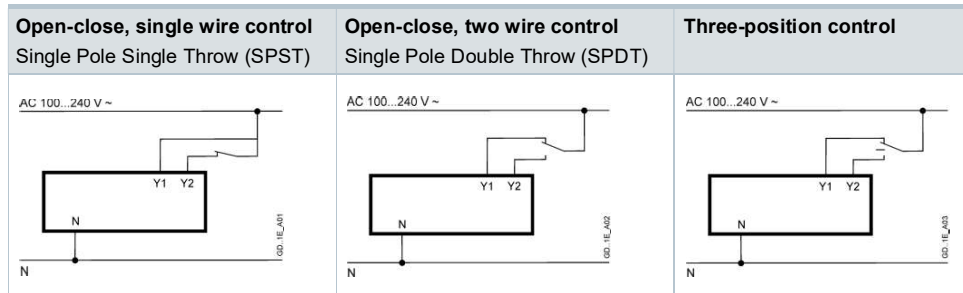

Cable labeling

Pin	Code	No.	Color	Abbreviation	Meaning
Actuators AC 24 V ~ / DC 24...48 V =	G	1	red	RD	System potential AC 24 V ~ / DC 24...48 V =
	G0	2	black	BK	System neutral
	Y1	6	purple	VT	Positioning signal AC/DC 0 V, "clockwise" (GDB141.9E)
	Y2	7	orange	OG	Positioning signal AC/DC 0 V, "counter-clockwise" (GDB141.9E)
	Y	8	grey	GY	Signal in (GDB161.9E)
Actuators AC 100...240 V ~	U	9	pink	PK	Signal out (GDB161.9E)
	N	4	blue	BU	Neutral conductor
	Y1	6	black	BK	Positioning signal AC 100...240 V ~, "clockwise" (GDB341.9E)
Modbus AC 24 V ~ DC 24 V =	Y2	7	white	WH	Positioning signal AC 100...240 V ~, "counter-clockwise" (GDB341.9E)
	REF	6	purple	VT	Reference (Modbus RTU)
	+	8	gray	GY	Bus + (Modbus RTU)
	-	9	pink	PK	Bus - (Modbus RTU)

Actuator

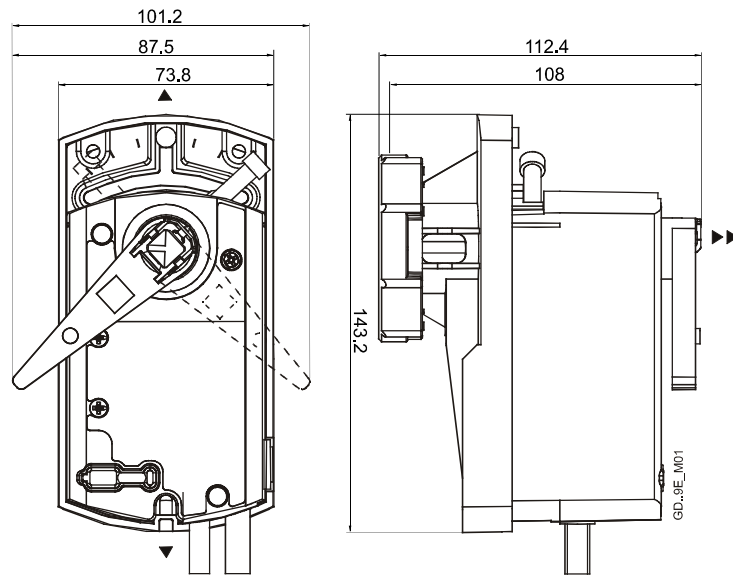

Dimensions in mm

▶	> 100	Minimum clearance from ceiling or wall for mounting, connection, operation, maintenance etc.
▶▶	> 200	

External Modbus converter

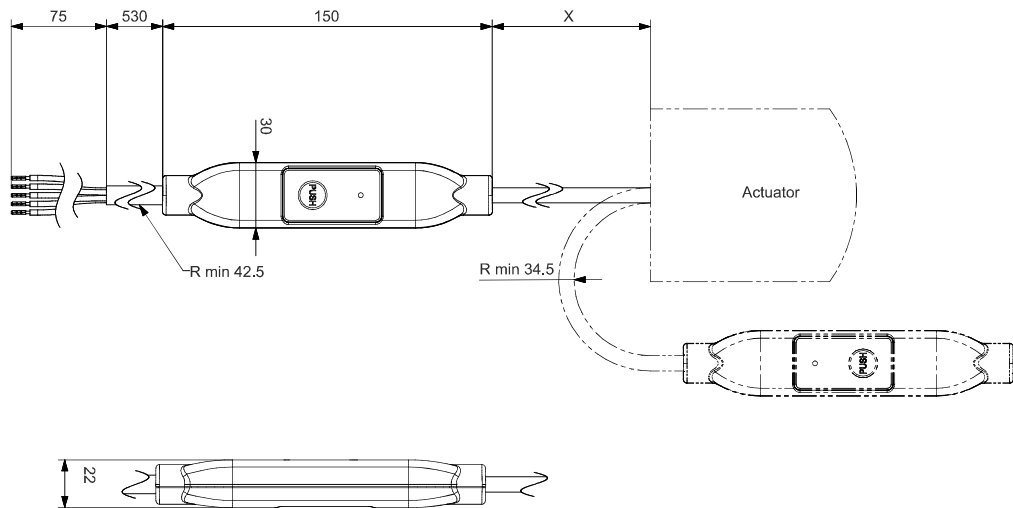

Temperature adapter (optional)

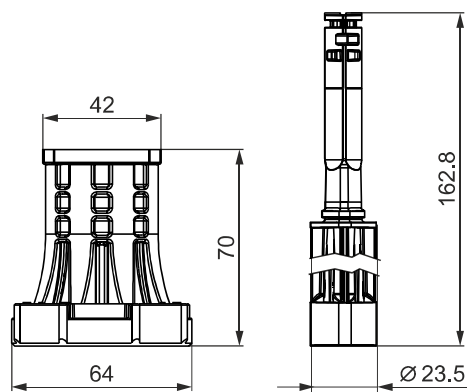

Revision numbers

Type	Valid from rev. no.
GDB141.9E	..B
GDB341.9E	..B
GDB161.9E	..B
GDB161.9E/MO	..A

Issued by
Siemens Switzerland Ltd
Smart Infrastructure
Global Headquarters
Theilerstrasse 1a
6300 Zug
Switzerland
Tel. +41 58-724 24 24
www.siemens.com/buildingtechnologies

© Siemens Switzerland Ltd, 2016 - 2025

Technical specifications and availability subject to change without notice.

Document ID A6V10636150_en--_n
Issue 2025-03-12