

Ultrasonic compact heat meters

WSM5.., WSM6..



Ultrasonic heat meters to measure flow and energy in hydronic heating or cooling circuits.

- Non-wearing due to non-moving parts
- Approved in accordance with EN 1434 and MID accuracy class 2
- Compact meter with flow measuring section
 - WSM5.. made of high-tech plastic
 - WSM6.. made of brass
- Mounting position optional (horizontal or vertical), heat or cold side
- Measuring range of flow 1:100 conforming to EN 1434 (total range 1:1000)
- Optical interface as per EN 62056-21
- M-bus wired or M-bus RF communication
- For use in the refrigeration circuit (optional)
- Self diagnostics

Use

The heat (WSM5../WSM6..) and cooling meters (WSB5../WSB6..) is a measuring instrument to physically acquire the energy consumption. The device consists of a flow measuring section made of high-tech plastic (WSx5..) or brass (WSx6..), 2 ready connected temperature sensors, and an electronic unit which calculates the energy consumption from the flow and temperature differential. The compact meter WS.. is of compact design and therefore ideally suited for use in apartments. It is available in different versions for metering heat (WSM..) or cooling (WSB..) energy.

Restrictions:

The temperature sensors and battery of the WS.. compact meters cannot be replaced.

Functions

Meter design

The meter consists of electronic unit, flow measuring section and 2 temperature sensors. The electronic unit is equipped with longlife batteries, ensuring up to 11 years of operation.

Ultrasonic measuring principle

The flow is acquired based on the non-wearing ultrasonic measuring principle, which requires no moving parts.

The amount of energy transferred from the medium to the consumer over a defined period of time is proportional to the temperature differential between the warmer and colder side and the volume of water that has passed through.

The water volume is measured in the measuring tube by ultrasonic pulses which are transmitted in the direction of flow and against the direction of flow. Downstream, the time difference between the transmitter and receiver is reduced, upstream it is increased. The water volume is calculated based on the difference in runtime.

The flow and return temperature is acquired by platinum resistors.

The water volume as well as the temperature difference between the warmer and cooler side is multiplied using a heat coefficient and the product is integrated. The result, which is the consumed amount of thermal energy, is stored and displayed in the physical unit kWh, the volume in m³.

The WS.. uses an intelligent, adaptive temperature-measuring interval. With changing system conditions (e.g. rapid increase of flow), the WS.. changes for a certain time to a fast temperature-measuring interval. Thus, the meter always adapts itself to the current situation and acquires the system temperatures very accurately.

Processor unit

A common electronic unit applies to all flow variables.

Optical communication interface

The WSM5.. is equipped with an optical communication interface which facilitates readout and configuration on site with the help of the optical read head WZR-OP-USP and matching UltraAssist software.

M-bus communication (optional)

The meter can be read out from a remote location via an M-bus master unit, if the meter uses M-bus communication.

M-bus RF communication (optional)

If the meter uses M-bus RF communication, it can be read out remotely.

Tampering

To open the device, the calibration seal at the top of the WS.. must be destroyed.

Self diagnostics

The meter continuously performs self-diagnostics, allowing it to detect a number of mounting or device errors and to display them.

Technical design

The diagram below shows the typical accuracy of the WSM5.. / WSM6.. compared to the error limits per EN 1434 class 2.

Metering accuracy as per EN 1434

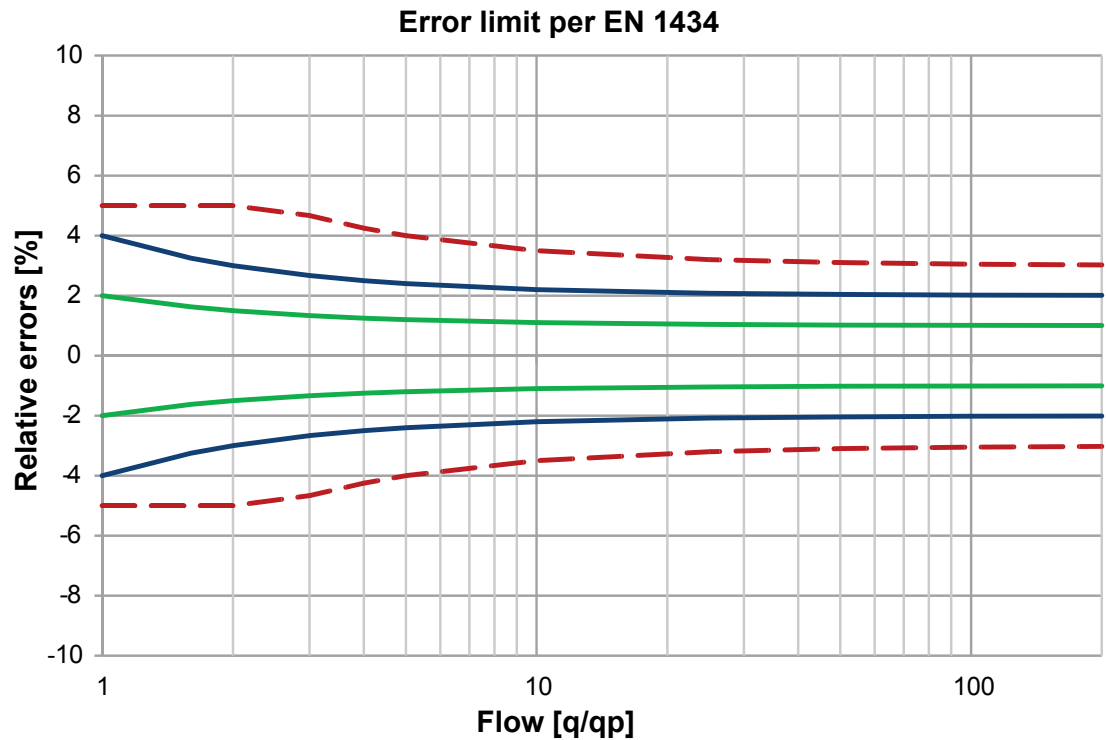

Key:

- - - EN 1434, class 3
- EN 1434, class 2
- WSM5.. / WSM6.. typical (EN 1434, ½ class 2)

The pressure loss in a flow sensor is indicated as nominal flow q_p .

Actual pressure loss at the indicated flow can be calculated using the K_v value, which indicates flow at 1 bar differential pressure:

$$\Delta p = 1 \text{ bar} \times (Q / K_v)^2$$

Δp = Pressure loss in bar

Q = Flow in m^3 / h

$K_v = K_v$ – Value at $\Delta p = 1$ bar

Pressure loss characteristic WSM5..

Nominal flow q_p m^3/h	Mounting length mm	PIN	Pressure loss at q_p mbar	K_v value at $\Delta p = 1$ bar m^3/h	Curve in the diagram
0.6	110	G $\frac{3}{4}$	75	2.2	A
1.5	110, 130	G $\frac{3}{4}$, G 1	135	4.1	B
2.5	130	G1	135	6.8	C

The value can also be read graphically using the diagram as an alternative.

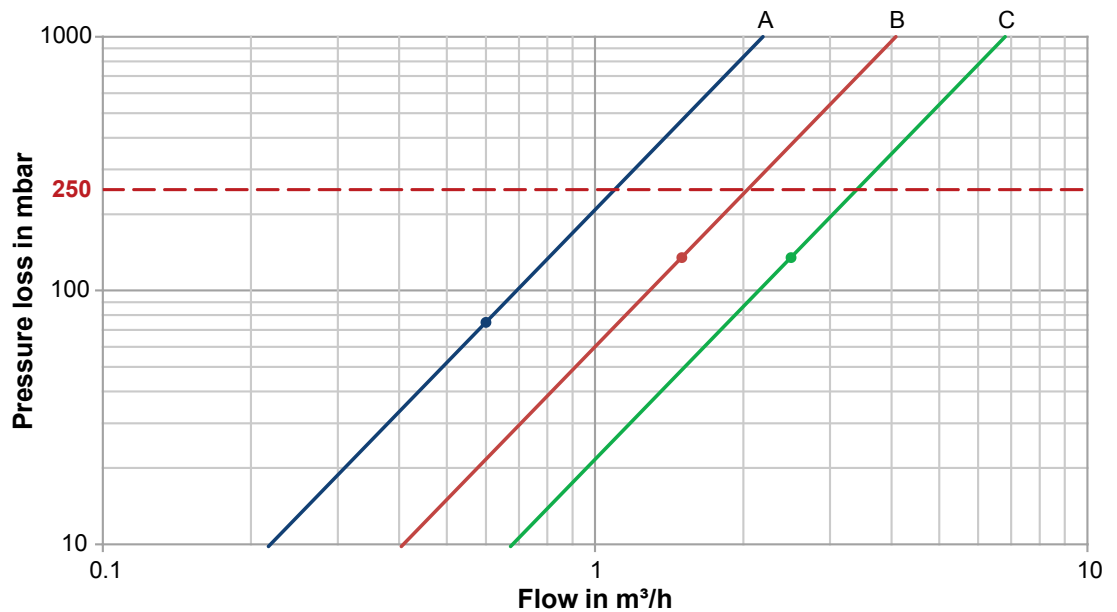

Pressure loss characteristic WSM6..

Nominal flow q_p m^3/h	Mounting length mm	Connection G/DN	Pressure loss at q_p mbar	K_v value at $\Delta p = 1$ bar m^3/h	Curve in the diagram
0.6	110, 190	G $\frac{3}{4}$	150	1.5	A
1.5	130, 190	G1	160	3.8	B
1.5	110	G $\frac{3}{4}$,	150	3.9	C
2.5	190	G1	210	5.3	D
2.5	130	G1	200	5.6	E

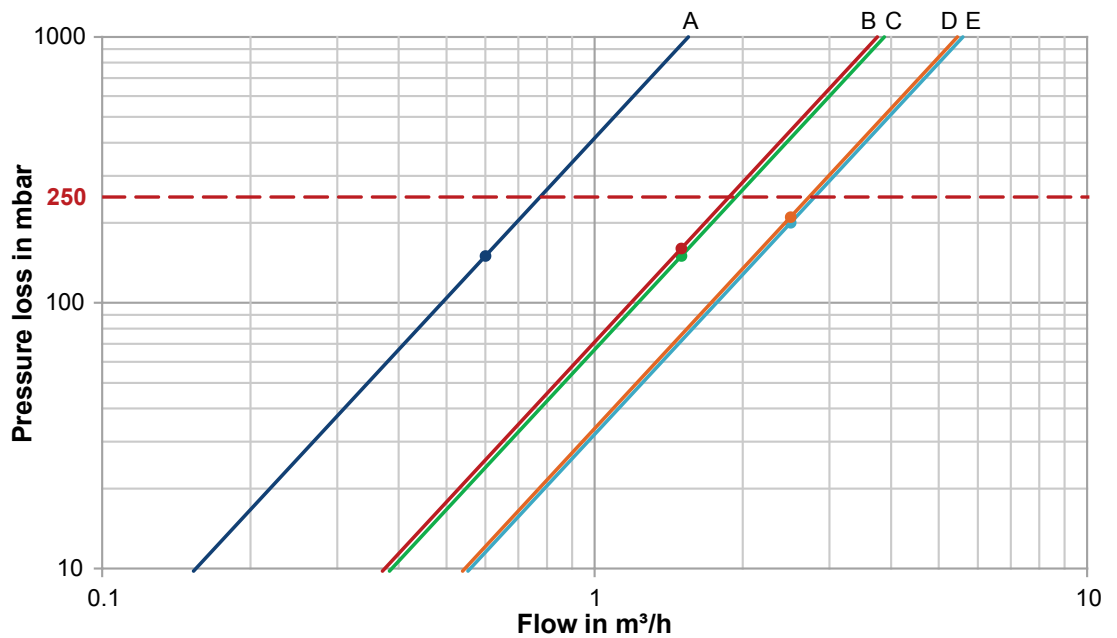

Display

The WS.. has a large, easy-to-read LCD with 7 digits to display different values (e.g. energy or flow). This new type of dynamic display enables users to identify positive flow at a glance. Icons for previous year values and previous month values support the easy-to-understand display concept.

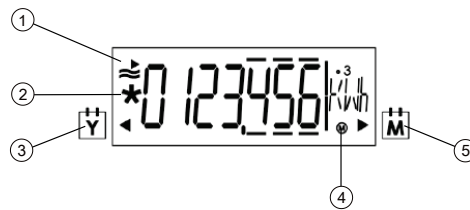

- | | | | |
|---|--|---|---|
| 1 | Activity indicator at flow | 4 | Icon for maximum |
| 2 | Star icon: Calibrated value | 5 | Icon for previous month value
Calibrated value |
| 3 | Icon for previous year value
Calibrated value | | |

The meter's display is subdivided into several loops.

A short press on the button (<2 s) lets the current loop pass through line by line. The first line displays again after the last line. A long press (>3 s) displays the first line of the next loop. The first loop is displayed again after the last loop.

The arrow icons mark the display of a stored value of the previous year or previous month. A calibrated value (e.g. energy) is marked on the display by a star symbol. The decimal places of displayed values are indicated by a frame.

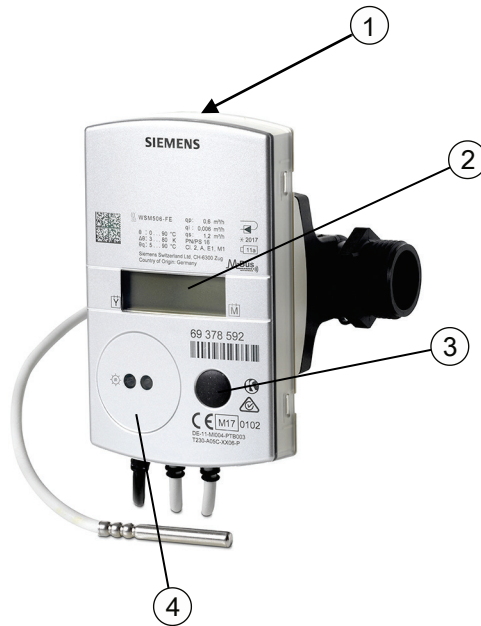

- | | | | |
|---|------------------|---|-------------------|
| 1 | Calibration seal | 3 | Optical interface |
| 2 | Display | 4 | Optical interface |

User loop LOOP 0		
1234567	kWh	Energy
1234567	m ³	Volume
0000000		Segment test
F-----		In case of error message with error code

Current values LOOP 1		
1234567	m ³ /h	Current flow rate
1234567	kW	Current thermal energy
80.0	°C	Current temperature heat side at 2 second exchange with cooler side
50.0	°C	Current temperature cold side
21.0	K	Temperature difference
Bd 1234	h	Runtime totalizer
Fd 123	h	Missing time
Pd 1234	h	Time with flow rate

Monthly values LOOP 2		
01.06.2011		Monthly date (due date) saving day
1234567	kWh	Monthly value (due date) energy on set day
1234567	m ³	Monthly value (due date) volume on set day

Fd 123	h	Missing time on set day
3.123	m ³ /h	Maximum flow rate
03.02.10		Date stamp of max. flow rate
279,4	kW	Maximum power
03.02.10		Date stamp of max. power
93.7	°C	Maximum temperate heat side
03.02.10		Date stamp max. temperature heat side
64.8	°C	Maximum temperate cold side
03.02.10		Date stamp max. temperature cold side

General / communication		
LOOP 3		
1234567		Device number, 7 digits
OMS		RF standard (M-bus RF only)
Unbind		Meter not connected (M-bus RF only)
Bind		Meter connected (M-bus RF only)
MbuS		Interface (only for M-bus)
127A		Primary address (only for M-bus)
0000000A		Secondary address (only for M-bus)
01.01		Due date (yearly set day)
01.--.--		Monthly value (monthly set day)
I 5-00	FW	Firmware version
CrC 1234		CRC code, part requiring calibration

Other		
LOOP 4		
17.11.11		Current date [TT.MM.JJ]
10.38.57		Current time of day [hh.mm.ss]
-----	C	Code entry for test/parameter operation

Error messages

The meter continuously performs self-diagnostics, allowing it to detect and display a number of mounting or device errors.

FL	nEG	Wrong direction of flow
DIFF	nEG	Negative temperature differential
F0		Flow cannot be measured
F1		Break in sensor heat side
F2		Break in sensor cold side
F3		Electronics for temperature assessment defective
F4		Battery empty, power supply problem
F5		Short circuit sensor, heat side

F6	Short circuit sensor, cold side
F7	Disruption of internal memory operation
F8	F1, F2, F3, F5 or F6 persist longer than 8 hours Detection of tampering No further measurements are made
F9	Error in the electronics

	NOTICE
	Manually reset message F8 in configuration mode or using the service software. All other error messages are deleted automatically as soon as the error is eliminated.

Previous year's values

The electronic unit stores the meter readings for energy, volume, missing time, and flow measuring time as well as the current maximum values of flow rate, power, temperature heat and cold side with their date stamps on a yearly set day.

The set day for previous year values can be parameterized.

Monthly values

The electronic unit stores the meter readings for energy, volume, missing time, and flow measuring time as well as the monthly maximum values of flow rate, power, temperature heat and cold side with their date stamp for up to 24 months on the set day of each month.

The set day for previous monthly values can be parameterized.

In addition, a second programmable monthly set day is available for 24 months – the day on which energy and volume are stored.

Standard parameters

The UH50.. comes programmed as follows:

- Set day [TT.MM]: 01.01

Type summary



Cooling energy meter WSB.. is available upon request.

Heat meter WSM..

The types of meters listed below are equipped as follows:	
Mounting location	In return
Rated pressure	PN 16
Length of control cable	1.5 m
Sensor mounting	Return sensor, integrated in the flow measuring section
Sensor type	Pt500, Ø 5.2 mm, length = 45 mm

Temperature sensor cable length	1.5 m
Approval	EN 1434 class 2 MID 2004/22/EG
Display	kWh

Heat meter with high-tech plastic flow measuring section WSM5..

Heat meter nominal flow 0.6 m³/h

Options	Order number	Type
Mounting length 110 mm, connecting thread G ¾", battery life 6 years without communication	LYU:WSM506-0A	WSM506-0A
Mounting length 110 mm, connecting thread G ¾", battery life 11 years without communication	S55561-F133	WSM506-0E
Mounting length 110 mm, connecting thread G ¾", battery life 11 years, M-bus	S55561-F194	WSM506-BE
Mounting length 110 mm, connecting thread G ¾", battery life 11 years, M-bus RF	S55561-F246	WSM506-FE

Heat meter nominal flow 1.5 m³/h

Options	Order number	Type
Mounting length 110 mm, connecting thread G ¾", battery life 6 years without communication	LYU:WSM515-0A	WSM515-0A
Mounting length 110 mm, connecting thread G ¾", battery life 11 years without communication	S55561-F135	WSM515-0E
Mounting length 110 mm, connecting thread G ¾", battery life 11 years, M-bus	S55561-F195	WSM515-BE
Mounting length 110 mm, connecting thread G ¾", battery life 11 years, M-bus RF	S55561-F247	WSM515-FE

Heat meter nominal flow 2.5 m³/h

Options	Order number	Type
Mounting length 130 mm, connecting thread G 1", battery life 6 years without communication	LYU:WSM525-0A	WSM525-0A
Mounting length 130 mm, connecting thread G 1", battery life 11 years without communication	S55561-F137	WSM525-0E
Mounting length 130 mm, connecting thread G 1", battery life 11 years, M-bus	S55561-F196	WSM525-BE
Mounting length 130 mm, connecting thread G 1", battery life 11 years, M-bus RF	S55561-F248	WSM525-FE

Heat meter with brass flow measuring section WSM6..

Options	Order number	Type
Nominal flow 0.6 m ³ /h Mounting length 110 mm, connecting thread G ¾", battery life 11 years, M-bus	S55561-F249	WSM606-BE
Nominal flow 1.5 m ³ /h Mounting length 110 mm, connecting thread G ¾", battery life 11 years, M-bus	S55561-F250	WSM615-BE
Nominal flow 2.5 m ³ /h Mounting length 130 mm, connecting thread G 1", battery life 11 years, M-bus	S55561-F251	WSM625-BE

Accessories

Mounting accessories only for meters with high-tech plastic flow measuring sections:

Accessories for WSM5..

Component	Order number	Type
Mounting kit G ¾", consisting of: 2x threaded connection G ¾" x R ½" 2x cap nuts G ¾" 2x gaskets G ¾"	LYU:T23-E34	T23-E34
Mounting kit G 1", consisting of: 2x threaded connection G 1" x R ¾" 2x cap nuts G 1" 2x gaskets G 1"	LYU:T23-E1	T23-E1
10x gaskets EPDM G ¾"	LYU:T23-34EPDM10	T23-34EPDM10
10x gaskets EPDM G 1"	LYU:T23-1EPDM10	T23-1EPDM10

Mounting accessories only for meters with brass flow measuring sections:

Accessories for WSM6..

Component	Order number	Type
Mounting kit G ¾", consisting of: 2x threaded connection G¾" x R½" 2x cap nuts G¾" 2x gaskets G¾"	S55563-F124	WZM-E34
Mounting kit 1", consisting of: 2x threaded connection G1" x R¾" 2x cap nuts G1" 2x gaskets G1"	S55563-F123	WZM-E1
Adapter piece 110 mm G¾" to 130 mm G¾": 1x extension G¾ B" to G¾ B" 1x gasket G¾"	LYU:WZM-V130	WZM-V130
Adapter piece 110 mm G¾" to 130 mm G1": 2x extension G¾ B" to G1 B" 2x gaskets G¾" 2x gaskets G1"	LYU:WZM-V130.G1	WZM-V130.G1

Adapter piece 110 mm G ¾" to 165 mm G¾": 1x extension G¾ B" to G¾ B" 1x gasket G¾"	LYU:WZM-VE165	WZM-VE165
Adapter piece 110 mm G¾" to 190 mm G1": 2x extension G¾ B" to G1 B" 2x gaskets G¾" 2x gaskets G1"	LYU:WZM-V190	WZM-V190
Sealing disk for thread G¾", threaded connection R½"	LYU:9060944002	9060944002
Sealing disk for thread G1", threaded connection R¾"	LYU:9060944003	9060944003
Mounting set for sensor Ø 5.2x45 mm, consisting of: - 1 sensor mount brass DS M10x1 mm - 1 O-ring - 1 dowel pin	LYU:9930127002	9930127002
Sealing disk for temperature sensor M10x1 mm, Ø 8.6/5.3x1 mm, hard fiber	LYU:9060944001	9060944001
Sealing disk for temperature sensor M10x1 mm, Ø 8.6/5.3x1.5 mm, copper	LYU:9060950	9060950
Sealing disk, copper, for protection pocket G ½" or adapter WZT-A12, Ø 27.9/ 21.2 mm x 1.5 mm	LYU:9060948	9060948

Mounting accessories for both compact meter types:

Accessories for WSM5../WSM6..

Component	Order number	Type
Ball valve R½" with union nut G¾"	LYU:WZT-K12-34	WZT-K12-34
Ball valve R¾ " with union nut G¾"	LYU:WZT-K34-34	WZT-K34-34
Ball valve R¾ " with union nut G1"	LYU:WZT-K34-1	WZT-K34-1
Ball valve R 1" with union nut G1"	LYU:WZT-K1-1	WZT-K1-1
Ball valve R½" to install a DS sensor M10 x 1 mm, length = 28 mm, max. 130°C, PN 25	S55563-F104	WZT-K12
Ball valve R¾" to install a DS sensor M10 x 1 mm, length = 28 mm, max. 130°C, PN 25	S55563-F120	WZT-K34
Ball valve R 1" to install a DS sensor M10 x 1 mm, length = 28 mm, max. 130°C, PN 25	S55563-F119	WZT-K1
Adapter G 3/8 B" with threaded hole M10x1 mm for sensor, including gasket G3/8" made of copper	LYU:WZT-A38	WZT-A38
Adapter G½ B" with threaded hole M10x1 mm for sensor, including gasket G½" made of copper	S55563-F116	WZT-A12
Adapter G¾ B" with threaded hole M10x1 mm for sensor, including gasket G¾" made of copper	LYU:WZT-A34	WZT-A34
Protection pocket G ½ B made of brass, Ø 5.2x35 mm for temperature sensor Ø 5.2x45 mm, including gasket G½", copper	S55563-F103	WZT-M35

Protection pocket G½ B" made of brass, Ø 5.2x50 mm for temperature sensor Ø 5.2x45 mm, including gasket G½", copper	LYU:WZT-M50	WZT-M50
Adapter kit consisting of: - 1 plastic sensor adapter Ø 5.2x45 mm - 1 mounting aid for sensor Ø 5.2x45 mm - 2 O-rings	LYU:9956230	9956230
Spacer G¾", length 110 mm, including 2 gaskets	LYU:WZM-G110	WZM-G110
Spacer G1", length 130 mm, including 2 gaskets	LYU:WZM-G130	WZM-G130
Welding sleeve with threaded hole for temperature sensor DS M10x1 mm	S55563-F121	WZT-G10
Self-lock seal with sealing wire	LYU:9956186001	9956186001
10 wall adapters for mounting the electronic unit on the wall, including 2 screws and 2 dowels	LYU:T23-WA10	T23-WA10

Programming accessories

Component	Order number	Type
Optical read head with USB plug for PC interface	LYU:WZR-OP-USB	WZR-OP-USB
Readout and configuration software: - UltraAssist	Download	-

Ordering

Please specify the quantity, order number, and type when ordering.

Scope of delivery

The ultrasonic heat meter is supplied complete with Mounting Instructions in different languages, an adapter kit, 2 gaskets and a seal.

Languages

The Installation Instructions are supplied in the following languages:

Bulgarian, Chinese, Czech, Dutch, English, French, German, Greek, Hungarian, Italian, Norwegian, Polish, Russian, Serbo-Croatian, Slovakian, Slovenian, Spanish and Turkish.

Product documentation

Related documents such as environmental declarations, CE declarations, etc., can be downloaded at the following Internet address:

<http://siemens.com/bt/download>

Installation

Flow measuring section

The mounting orientation is optional, the mounting location (heat or cold side) must correspond to the type of meter used.

Settling paths upstream of and downstream from the meter are not required. If the meter is installed in the common return of 2 heating circuits (e.g. space heating and DHW), the mounting location must be in an adequate distance from the T-piece (min. 10 x DN) to allow the different water temperatures to properly mix.

Before mounting the meter, the system must be properly flushed.

Mount the flow measuring section between 2 shutoff valves with the arrow pointing in the direction of flow. The sensors must be mounted in the same water circuit as the flow measuring section (observe mixing). The sensors can be fitted in T-pieces or ball valves, or can be immersed, either directly or in pockets (observe all national regulations). In any case, the end of the sensors' probe must extend to at least the pipe center. Temperature sensors and fittings must be sealed to prevent tampering.

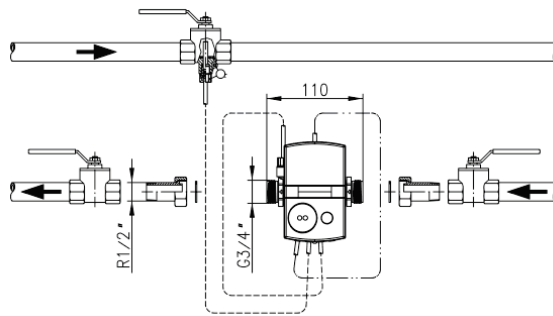

Mounting with ball valve

Processor unit

The ambient temperature of the processor unit cannot exceed 55 °C. Avoid direct sunlight. With water temperatures between 10 °C and 90 °C, the electronic unit can be left on the flow measuring section or can be fitted to a wall (detached mounting). The adapter plate on the wall or the flow measuring section can be aligned as needed to ensure ease of reading. To remove the electronic unit, turn the housing by 45° to the side and lift it up.

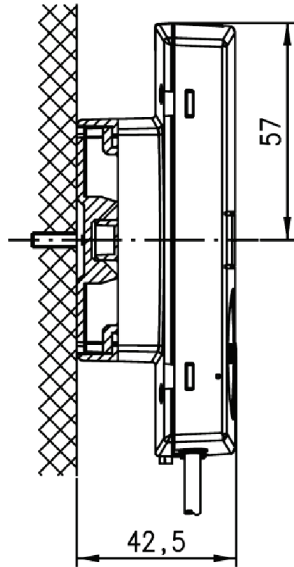

Wall mounting

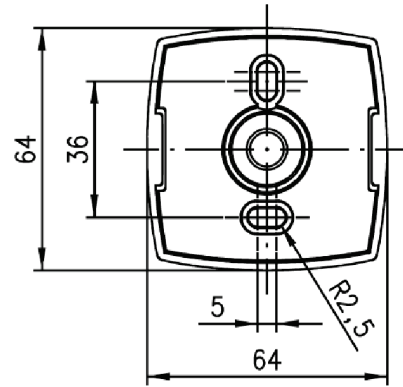

Wall adapter (view from above)

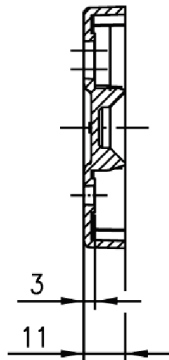

Wall adapter (side view)

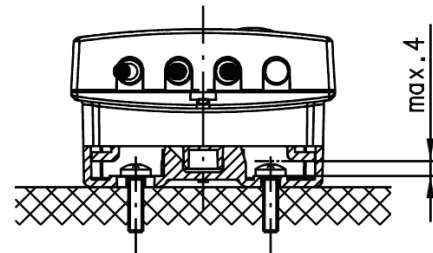

Maximum screw head height
(if using the wall bracket)

Maintenance

The meters are maintenance-free.
Observe all national calibration regulations.

Disposal

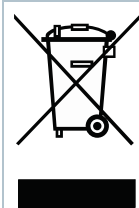

The device is considered an electronic device for disposal in accordance with the European Guidelines and may not be disposed of as domestic garbage.

- Dispose of the device through channels provided for this purpose.
- Comply with all local and currently applicable laws and regulations.
- Dispose of empty batteries in designated collection points.

Warranty

The application-related technical data is only guaranteed together with the products mentioned in this Data Sheet. Siemens rejects any and all warranties in the event that third-party products are used

Technical data

Processor unit

Power supply	
Battery type	Lithium battery (cannot be replaced)
Battery voltage	3.6 V
Battery life	6 or 11 years

Function data	
Measuring range	0...180 °C
Range of temperature differential $\Delta\Theta$	3 ... 80 K
Temperature response threshold	0.2 K
Thermal coefficient	Shifting compensated
Temperature-measuring error without sensor	$(0.5 + \Delta\Theta_{\min.}/\Delta\Theta)$ %, max. 1.5 % at $\Delta\Theta = 3$ K

Temperature sensor.	
Sensing element	Pt500
Type	Ø 5.2 x 45 mm

Flow measuring section

Function data				
Temperature range (national approvals may differ)		5...90 °C (plastic flow measuring sections) 5...105 °C (brass flow measuring section)		
Maximum temperature t_{\max}	°C	90		
Rated pressure	MPa	1.6 (PN 16)		
Nominal flow q_p	m ³ /h	0.6	1.5	2.5
Metrological class		1:100	1:100	1:100
Maximum flow q_s	m ³ /h	1.2	3	5
Minimum flow q_i	l/h	6	15	25
Response threshold	l/h	1.2	3	5
Pressure drop at q_p				
• Mounting length 110 mm Δp	mbar	75 ¹⁾ / 150 ²⁾	135 ¹⁾ / 150 ²⁾	---
• Mounting length 130 mm Δp	mbar	---	135 ¹⁾ / 160 ²⁾	165 ¹⁾ / 200 ²⁾
Flow rate at $\Delta p = 1$ bar, K_v , m ³ /h		2.2 ¹⁾ / 1.5 ²⁾	4.1 ¹⁾ / 3.9 ²⁾	6.8 ¹⁾ / 5.6 ²⁾
Mounting position		Any		
1) Plastic flow measuring section 2) Brass flow measuring section				

Communication	
Optical interface	
<ul style="list-style-type: none"> • Basic design • Protocol 	Similar to EN 62056-21 Per EN 13757-2 / -3
M-bus wired interface	Option
<ul style="list-style-type: none"> • Voltage V_{max}. 	50 V
<ul style="list-style-type: none"> • Power consumption 	1 M-bus load
<ul style="list-style-type: none"> • Address 	Primary or secondary
<ul style="list-style-type: none"> • Baud rate 	300 or 2400 baud
<ul style="list-style-type: none"> • Max. permissible reading frequency 	1x per minute
<ul style="list-style-type: none"> • Protocol 	As per EN 13757-2/-3, EN 1434-3
<ul style="list-style-type: none"> • Connection cable length and cross section 	1.5 m, 2x AWG24/0.2 mm ²
M-bus RF interface	Option
<ul style="list-style-type: none"> • Transmission frequency 	868.95 MHz (868.90 ... 869.00 MHz)
<ul style="list-style-type: none"> • Transmitter power 	Min. 3.16 mW (5 dBm) to max. 25 mW (13.9 dBm)
<ul style="list-style-type: none"> • Power supply 	Max. 3 AA batteries
<ul style="list-style-type: none"> • Send heartbeat <ul style="list-style-type: none"> – Mobile data acquisition – Stationary data acquisition – User defined telegrams 	20...34 s 15 minutes 12...900 s (depending on telegram length)
Protocol	Per EN 13757-4
Cable length, control cable	1.5 m

Housing type	
Protection class	III
IP class	
<ul style="list-style-type: none"> • Processor unit • Flow measuring section 	IP54 WSM5...: IP65, WSM6...: IP54

Environmental conditions			
	Operation	Transportation	Storage
	EN 60721-3-3	EN 60721-3-2	EN 60721-3-1
Climatic conditions	Class A	Class A	Class A
Temperature	5...55 °C	-20...60 °C	-20...60 °C
Humidity	<93% r.h. at 25 °C (non-condensing)	<93% r.h. at 25 °C (non-condensing)	<93% r.h. at 25 °C (non-condensing)
Mechanical conditions	Class M1	Class M1	Class M1
Max. altitude	Min. 700 hPa, corresponding to max. 2000 m above sea level		

Standards, guidelines	
Product standards	DIN EN 1434-x (heat meters)
EU Conformity (CE)	CE2T5372xx *)
RCM Conformity	CE2T5372en_C1 *)

Environmental compatibility
The product environmental declaration CE2E5372en *) contains data on environmentally compatible product design and assessments (RoHS compliance, material composition, packaging, environmental benefit, and disposal).

Dimensions (W x H x D)	
Processor unit	116 x 71 x 32 mm
Flow measuring section	See "Dimensions"

Housing material	
Cover	ABS
Bottom section	PC-GF10
Battery compartment	PC clear

Housing color	
Cover	RAL 9006
Bottom section	RAL 9002

Weight	
Unit complete with accessories	WSM506..: 0.52 kg WSM515..: 0.52 kg WSM525..: 0.56 kg WSM606..: 0.80 kg WSM615..: 0.76 kg WSM625..: 0.84 kg

*) Documents can be downloaded at <http://www.siemens.com/bt/download>.

Connection diagram

For meters with M-bus communication

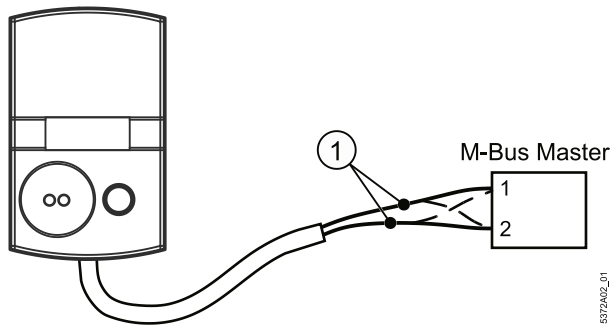

1 Brown / white

Dimensions

WSM5..

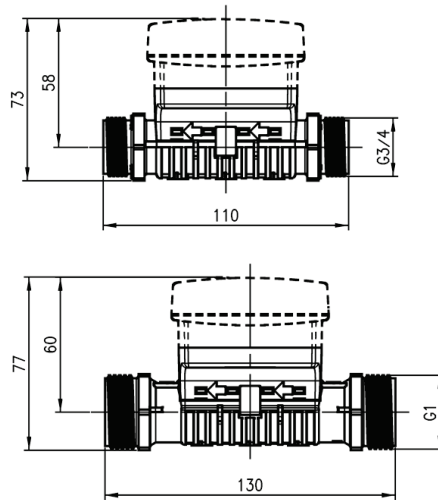

WSM6..

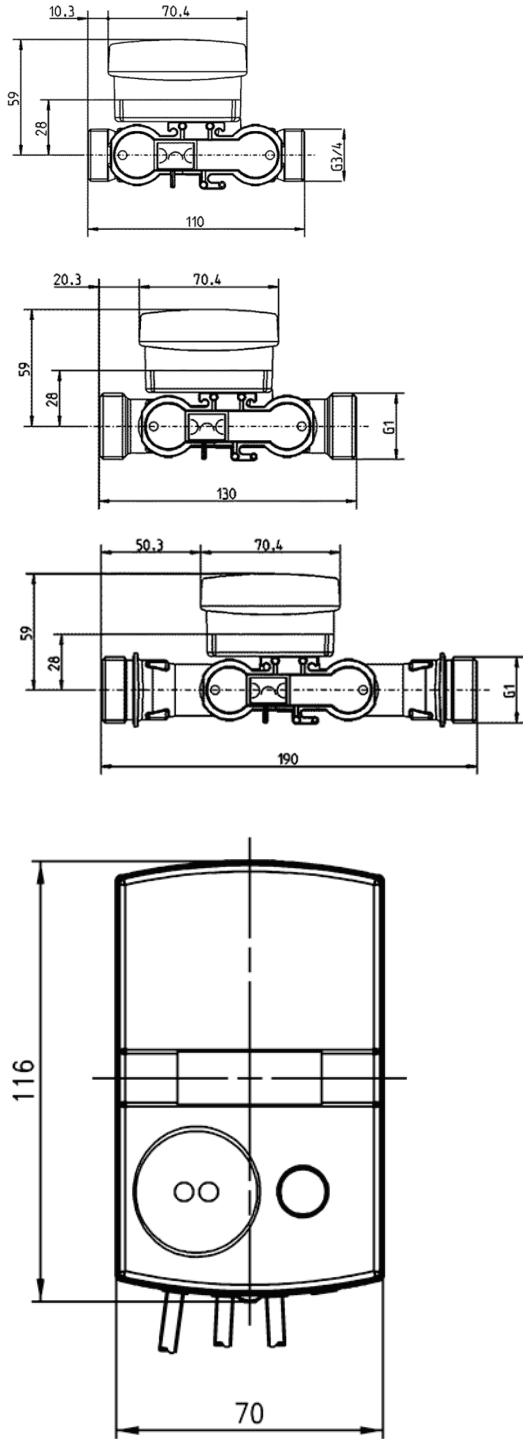

Dimensions in mm

Issued by
Siemens Switzerland Ltd
Building Technologies Division
International Headquarters
Gubelstrasse 22
CH-6300 Zug
Tel. +41 58 724 2424
www.siemens.com/buildingtechnologies

© Siemens Switzerland Ltd, 2012
Technical specifications and availability subject to change without notice.