



DN 15 and DN 25



DN 40...150

Acvatix™

3-port seat valves PN40 with flanged connection VXF61..

- Cast steel GP240GH valve body
- DN 15...150
- k_{vs} 1.9...300 m³/h
- Can be equipped with SKD.., SKB.. and SKC.. electrohydraulic actuators

Use

For use in district heating, heating, ventilating, and air conditioning systems as a control valve for "mixing" and "diverting" functions.

For closed or open circuits.

Type summary

Product number	DN	k_{vs} [m ³ / h]	S_v
VXF61.14	15	1.9	> 50
VXF61.15		3	
VXF61.24	25	5	
VXF61.25		7.5	> 100
VXF61.39	40	12	> 50
VXF61.40		19	
VXF61.49	50		
VXF61.50		> 100	49
VXF61.65	65		
VXF61.80	80		
VXF61.90	100		
VXF61.91	125		
VXF61.92	150		

DN = Nominal size

k_{vs} = Nominal flow rate of cold water (5...30 °C) through the fully open valve (H_{100}) by a differential pressure of 100 kPa (1 bar)

S_v = Rangeability k_{vs} / k_{vr}

k_{vr} = Smallest k_v value, at which the flow characteristic tolerances can still be maintained, by a differential pressure of 100 kPa (1 bar)

Special versions

Product number	Type suffix	Description	Examples
VXF61..2	2	Sealing gland with PTFE sleeve, for 220...350 °C with thermal insulator	VXF61.242

Accessories

Product number	Description
ASZ6.5	Electric stem heating element, AC 24 V / 30 W, required for media below 0 °C

Ordering

Example:

Product number	Stock number	Designation	Quantity
VXF61.50	VXF61.50	3-port seat valve PN40 with flanged connection	1

Delivery

Valves, actuators and accessories are packed and supplied separately.

The valves are supplied without counter-flanges and without flange gaskets.

The thermal insulator of special version with type suffix 2 is factory-mounted in the valve on delivery.

This thermal insulator cannot be retrofitted or ordered separately

Spare parts, Rev. no.

See overview, page 9.

Equipment combinations

Valves	H ₁₀₀ [mm]	Actuators					
		SKD.. ¹⁾		SKB..		SKC..	
		Mixing	Diverting ²⁾	Mixing	Diverting ²⁾	Mixing	Diverting ²⁾
Δp _{max} [kPa]							
VXF61.14	20	1200	500	1600	500		
VXF61.15							
VXF61.24							
VXF61.25							
VXF61.39							
VXF61.40							
VXF61.49							
VXF61.50							
VXF61.65	40					800	350
VXF61.80						500	250
VXF61.90						300	150
VXF61.91						200	100
VXF61.92						125	70

¹⁾ Usable up to maximum medium temperature of 150 °C

²⁾ If noise is permitted, the same values apply as for mixing.

H₁₀₀ = Nominal stroke

Δp_{max} = Maximum permissible differential pressure across the valve (mixing: port A-AB, B-AB, diverting: port AB-A, AB-B), valid for the entire actuating range of the motorized valve

Actuator overview

Product number	Actuator type	Operating voltage	Positioning signal	Spring return	Positioning time	Positioning force	Data sheet	
SKD32.50	Electro-hydraulic	AC 230 V	3-position	No	120 s	1000 N	N4561	
SKD32.21				Yes	30 s			
SKD32.51				AC 24 V	No			120 s
SKD82.50		Yes			30 s			
SKD82.51		No						
SKD60		Yes						
SKD62..		DC 0...10 V ¹⁾		Yes				
SKB32.50	Electro-hydraulic	AC 230 V	3-position	No	120 s	2800 N	N4564	
SKB32.51				Yes				
SKB82.50				AC 24 V				No
SKB82.51		Yes						
SKB60		DC 0...10 V ¹⁾						No
SKB62..		Yes						
SKC32.60	Electro-hydraulic	AC 230 V	3-position	No	120 s	2800 N	N4566	
SKC32.61				Yes				
SKC82.60				AC 24 V				No
SKC82.61		Yes						
SKC60		DC 0...10 V ¹⁾						No
SKC62..		Yes						

¹⁾ or DC 4...20 mA or 0...1000 Ω

Pneumatic actuators

Pneumatic actuators are available on request from your local office.



Application is possible only if the VXF61.. is used as a mixing valve!

Valve cross section

Depending on the nominal size, a guided parabolic, perforated or slot plug is used that is directly connected to the valve stem. The seats are screwed to the valve body with the aid of special gland material.

DN 15 and DN 25

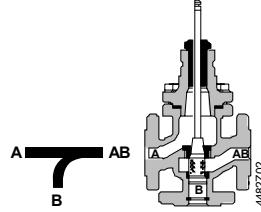

DN 40...150

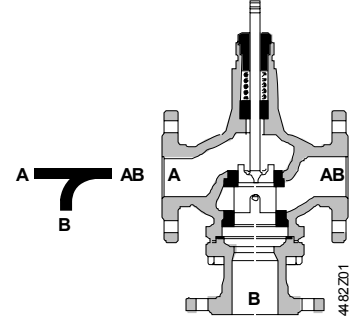

Thermal insulator

Thermal insulator for special version with type suffix 2, required for media from 220 °C to 350 °C; factory-mounted on the valve on delivery.

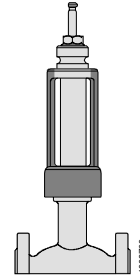

Sizing

Flow diagram "Mixing"

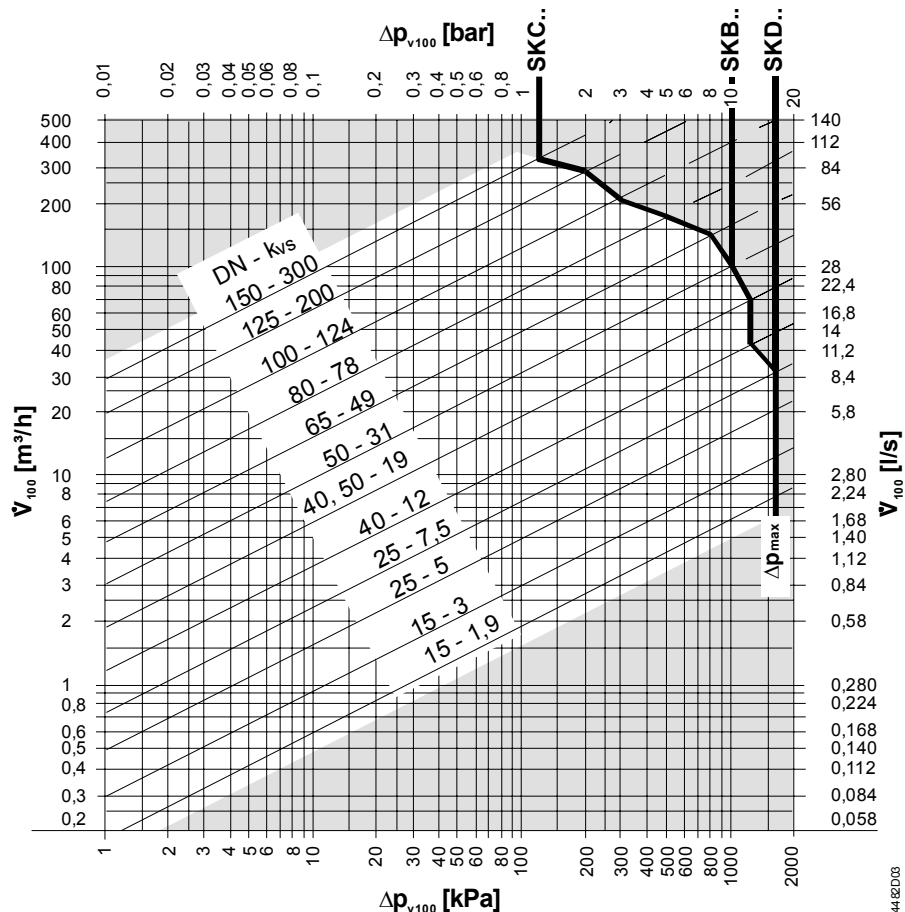

- Δp_{max} = Maximum permissible differential pressure across the valve (mixing: port A-AB, B-AB, diverting: port Tore AB-A, AB-B), valid for the entire actuating range of the motorized valve
- Δp_{v100} = Differential pressure across the fully open valve and the valve's control path A → AB, B → AB by a volume flow V_{100}
- V_{100} = Volumetric flow through the fully open valve (H_{100})
- 100 kPa = 1 bar ≈ 10 mWC
- 1 m^3/h = 0.278 l/s water at 20 °C

Valve flow characteristic

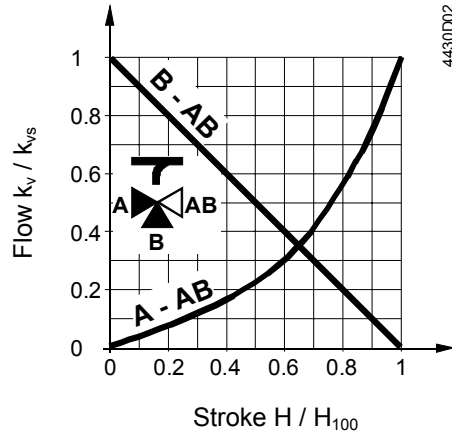

Through-port

0...30 %: linear
 30...100 %: $\eta_{gl} = 3$ as per VDI / VDE 2173

Bypass

0...100 %: linear

Mixing: Flow from port A and port B to port AB

Diverting: Flow from port AB to port A and port B

Port AB = constant flow

Port A = variable flow

Port B = bypass (variable flow)

Use the 3-port valve primarily as a mixing valve.

Working pressure and medium temperature

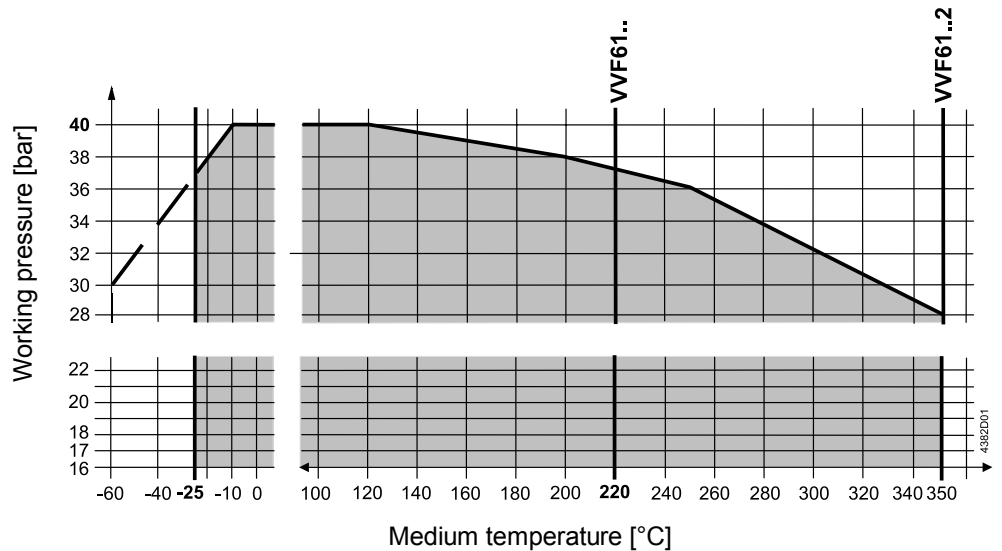

Working pressure and medium temperature staged as per ISO 7005

Current local legislation must be observed.

Notes

Engineering

We recommend installation in the return pipe, as the temperatures in this pipe are lower for applications in heating systems, which in turn, extends the stem sealing gland's life.



In open circuits the valve plug may seize as the result of scale deposits. In these applications, only the most powerful SKB.. or SKC.. actuators should be used. Further the valve should be exercised at regular intervals (two to three times per week). A strainer **MUST** be fitted at the valve inlet



To ensure the reliability of the valve, we recommend the fitting of a strainer at the valve inlet even in closed circuits.



For media below 0 °C, use the electric ASZ6.5 stem heating element to prevent the valve stem from freezing in the sealing gland. For safety reasons, the stem heating element has been designed for AC 24 V / 30 W operating voltage.

Mounting

Both valve and actuator can easily be assembled at the mounting location. Neither special tools nor adjustments are required.

The thermal insulator for thermo oil applications is factory-mounted. The actuator is directly mounted on the thermal insulator instead of the valve

The valve is supplied with Mounting Instructions 74 319 0519 0.

Orientation

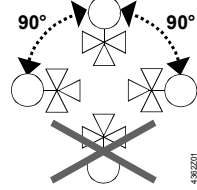

Direction of flow

When mounting, pay attention to the valve's flow direction symbol →.

Mixing from
A / B to AB



Diverting from
AB to A / B

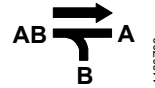

Commissioning



Commission the valve only if the actuator has been mounted correctly.

Valve stem retracts: through-port A – AB opens, bypass B closes
Valve stem extends: through-port A – AB closes, bypass B opens

Maintenance

Warning



VXF61.. valves require no maintenance.

When doing service work on the valve / actuator:

- Deactivate the pump and turn off the power supply
 - Close the shutoff valves
 - Fully reduce the pressure in the piping system, allow pipes to completely cool down
- If necessary, disconnect the electrical wires.

Before putting the valve into operation again, make certain the actuator is correctly fitted.

Stem sealing gland

The glands can be exchanged without removing the valve, provided the pipes are depressurized and cooled off and the stem surface is unharmed.
If the stem is damaged in the gland range, replace the entire stem-plug-unit.
Contact your local office or branch.

Disposal



Before disposal the valve must be dismantled and separated into its various constituent materials.

Legislation may demand special handling of certain components, or it may be sensible from an ecological point of view.

Current local legislation must be observed.

Warranty

The technical data given for these applications is valid only in conjunction with the Siemens actuators as detailed under "Equipment combinations", page 3.
All terms of the warranty will be invalidated by the use of actuators from other manufacturers.

Technical data

Functional data	PN class	PN 40 to ISO 7268
	Working pressure	to ISO 7005 within the permissible "medium temperature" range according to the diagram on page 5
	Flow characteristic	
	through-port	0...30 % linear 30...100 % equal percentage; $n_{gl} = 3$ to VDI / VDE 2173
	bypass	0...100 % linear
	Leakage rate	
	through-port	0...0.02 % of k_{vs} value to DIN EN 1349
	bypass	0.5...2 % of k_{vs} value to DIN EN 1349
	Permissible media	water chilled water, cooling water, low temperature hot water, high temperature hot water, water with anti-freeze; recommendation: water treatment to VDI 2035
		brine
		heat transfer oils
	Medium temperature	
	water, brine ¹⁾	VVF61.. -25...220 °C
heat transfer oils ²⁾	VVF61.. ≤ 220 °C VVF61..2 220...350 °C	
Rangeability S_v	DN 15...25: >50 (VXF61.25: >100) DN 25...150: >100	
Nominal stroke	DN 15...50: 20 mm DN 65...150: 40 mm	
Industry standards	Pressure Equipment Directive	PED 97/23/EC
	Pressure Accessories	as per article 1, section 2.1.4
	Fluid group 2	DN 15...25 without CE-marking as per article 3, section 3 (sound engineering practice) DN 40...80 category I, with CE-marking DN 100...150 category II, with CE-marking, test authority number 0036
Environmental compatibility	ISO 14001 (Environment) ISO 9001 (Quality) SN 36350 (Environmentally compatible products) RL 2002/95/EG (RoHS)	
Materials	Valve body	cast steel GP240GH
	Stem	stainless steel
	Plug, seats	stainless steel
	Sealing gland	stainless steel
	Gland materials	PTFE sleeves Special versions: VXF61..2: PTFE sleeve
Dimensions / Weight	Refer to "Dimensions", page 8	
	Flange connections	to ISO 7005

¹⁾ Electric stem heating element ASZ6.5 required for media below 0 °C

²⁾ For 220...350 °C with thermal insulator, type suffix 2. Use electrohydraulic SKB.. or SKC.. actuators.

Dimensions

Dimensions in mm

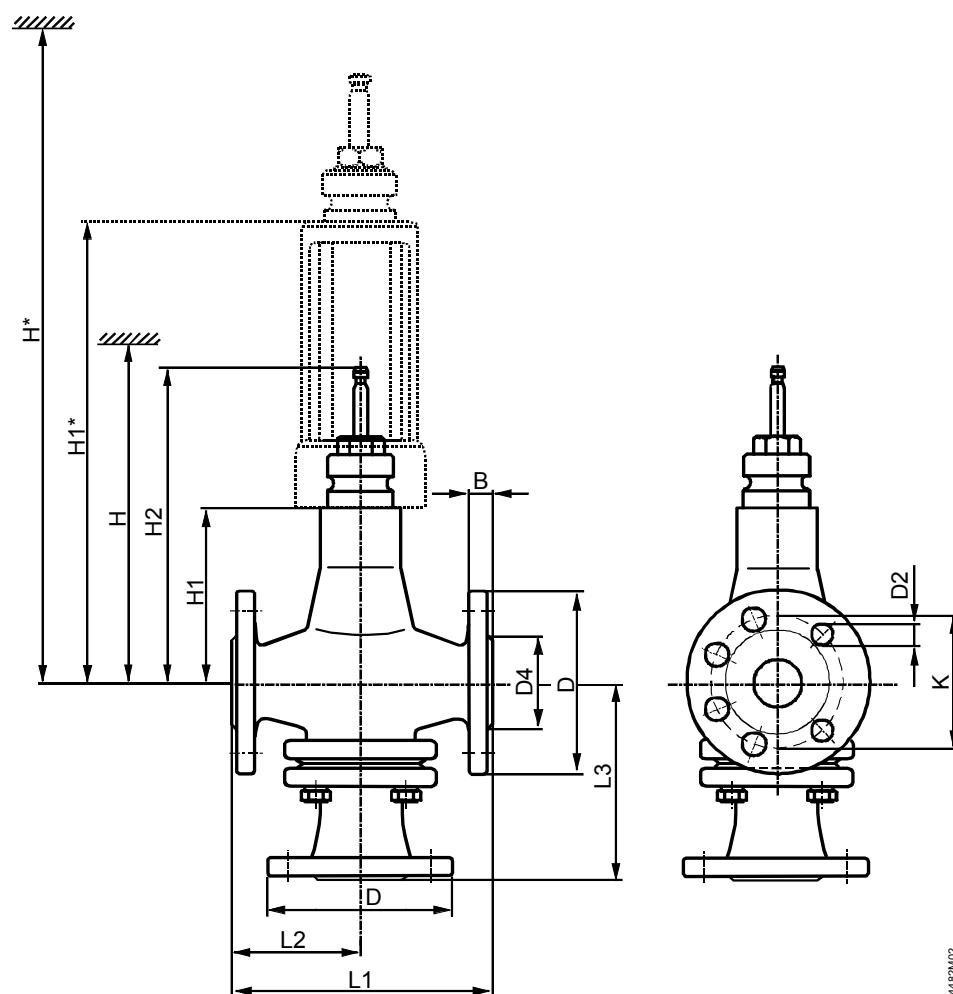

4482M02

DN	B	D Ø	D2 Ø	D4 Ø	K	L1	L2	L3	H1	H2	H			H1*	H*			kg	
											SKD..	SKB..	SKC..		SKD..	SKB..	SKC..	VXF61..	VXF61..2
15	16	95	14 (4x)	46	65	130	65	65	96	192.5	>496	>671		276	>676	>851		6.3	9.6
25	18	115		67	85	160	80	80	111	207.5	>511	>686		291	>691	>866		9	12.3
40	20	150	18 (4x)	84	110	200	100	162	136	232.5		>711	316		>891		18.5	22	
50		165		99	125	230	115	170									21.5	25	
65	22	185	18 (8x)	118	145	290	145	215	162	278.5		>737	342		>917	35	38.5		
80	200	132		160	310	155	230	170	286.5	>745			350			>925	42	45.5	
100	24	235	22 (8x)	156	190	350	175	250	180	296.5		>755	360		>935	61.5	65		
125	26	270	184	220	400	200	280	200	316.5	>775			380			>955	85.5	89	
150	28	300	26 (8x)	211	250	480	240	305	225	341.5		>800	405		>980	126	129.5		

DN = Nominal size

H = Total actuator height plus minimum distance to the wall or the ceiling for mounting, connection, operation, maintenance etc.

H1 = Dimension from the pipe centre to install the actuator (upper edge)

H2 = Valve in the «Closed» position means that the stem is fully extended

Spare parts

Order numbers for spare parts

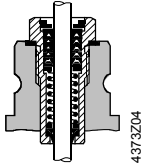
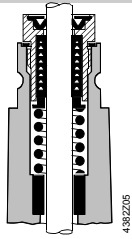
Product number	DN	Sealing gland			Set	
		VXF61..	VXF61..2	VXF61..	VXF61..	VXF61..2
						
						
					Plug with stem, circlip, sealing	
VXF61.14	15	4 284 8829 0	4 284 8829 0		74 676 0160 0	
VXF61.15	15	4 284 8829 0	4 284 8829 0		74 676 0136 0	
VXF61.24	25	4 284 8829 0	4 284 8829 0		74 676 0029 0	
VXF61.25	25	4 284 8829 0	4 284 8829 0		74 676 0030 0	
VXF61.39	40		4 284 8829 0	4 679 5630 0	74 676 0044 0	74 676 0091 0
VXF61.40	40		4 284 8829 0	4 679 5630 0	74 676 0045 0	74 676 0092 0
VXF61.49	50		4 284 8829 0	4 679 5630 0	74 676 0069 0	74 676 0093 0
VXF61.50	50		4 284 8829 0	4 679 5630 0	74 676 0070 0	74 676 0094 0
VXF61.65	65		4 284 8829 0	4 679 5630 0	74 676 0071 0	74 676 0083 0
VXF61.80	80		4 284 8829 0	4 679 5630 0	74 676 0072 0	74 676 0084 0
VXF61.90	100		4 284 8829 0	4 679 5630 0	74 676 0073 0	74 676 0085 0
VXF61.91	125		4 284 8829 0	4 679 5630 0	74 676 0074 0	74 676 0086 0
VXF61.92	150		4 284 8829 0	4 679 5630 0	74 676 0075 0	74 676 0087 0

Revision numbers

Product number	Valid from rev. no.	Product number	Valid from rev. no.
VXF61.14	..04	VXF61.142	..04
VXF61.15	..04	VXF61.152	..04
VXF61.24	..04	VXF61.242	..04
VXF61.25	..04	VXF61.252	..04
VXF61.39	..02	VXF61.392	..02
VXF61.40	..02	VXF61.402	..02
VXF61.49	..02	VXF61.492	..02
VXF61.50	..02	VXF61.502	..02
VXF61.65	..02	VXF61.652	..02
VXF61.80	..02	VXF61.802	..02
VXF61.90	..02	VXF61.902	..02
VXF61.91	..02	VXF61.912	..02
VXF61.92	..02	VXF61.922	..02

