



## Electromotoric actuators

**SSC31**  
**SSC81**  
**SSC61..**

for valves VVP45..., VXP45..., VMP45..

- 
- **SSC31**      operating voltage AC 230 V      3-position control signal
  - **SSC81**      operating voltage AC 24 V      3-position control signal
  - **SSC61**      operating voltage AC / DC 24 V      DC 0...10 V control signal
  - **SSC61.5**    same as SSC61, plus electrical fail-safe function
  - **Nominal force 300 N**
  - **Automatic identification of valve stroke**
  - **Direct mounting with coupling nut, no tools required**
  - **Cable connection via screw terminals**
  - **Manual override with indication of position and direction of travel**
  - **Parallel connection of multiple actuators**

### Use

---

For operation of Siemens valves of the V..P45.. range for water-side control of hot and cooling water in heating, ventilation and air conditioning systems.

In conjunction with the ASK30 mounting kit, the former Landis & Gyr valves VVG45..., VVG45.. and X3i.. can also be operated.

## Type summary

### Standard versions

Type reference	Operating voltage	Running time at 50 Hz	Positioning signal	Remarks
SSC31	AC 230 V	150 s	3-position	
SSC81	AC 24 V			
SSC61	AC / DC 24 V	30 s	DC 0...10 V	
SSC61.5				

### Accessories

Type reference	Description
ASK30	Mounting kit for use with former Landis & Gyr valves VVG45..., VXG45... and X3i..

### Ordering

When ordering, please give quantity, product name and type reference.

Example: 2 actuators SSC81

### Delivery

The actuators, valves and accessories are packed separately. Items are supplied individually packed.

### Equipment combinations

Type reference	Type of valve	$k_{vs}$ [m <sup>3</sup> /h]	PN class	Data Sheet
VVP45..	2-port valves	0.25...25	PN 16	N4845
VXP45..	3-port valves			
VMP45..	3-port valves with T-bypass	0.25...4		
VVG45.. <sup>1)</sup>	2-port valves	0.63...25		Retrofitting to former Landis & Gyr valves
VXG45.. <sup>1)</sup>	3-port valves			
X3i.. <sup>1)</sup>	3-port valves			

<sup>1)</sup> With ASK30 mounting kit

### Function / mechanical design

When the actuator is driven by a 3-position or DC 0...10 V control signal, it generates a stroke which is transmitted to the valve stem.

#### 3-position control signal

SSC31 / SSC81

- Voltage at Y1: Actuator stem extends valve opens
- Voltage at Y2: Actuator stem retracts valve closes
- No voltage at Y1 or Y2: Actuator maintains the current position

#### DC 0...10 V control signal

SSC61...

- The valve opens / closes in proportion to the control signal at Y.
- At DC 0 V, the valve is fully closed (A → AB).
- When power supply is removed, the actuator maintains its current position.

#### Electrical fail-safe function

SSC61.5

When first connected to power, or after a power failure, the capacitor which stores energy for the fail-safe function will be charged. This process takes up to 180 seconds.

While the capacitor is being charged, the actuator cannot respond to any Y control signals.

On completion of the charging process and self-calibration (see below), the "Open" and "Close" travel are proportional to the DC 0...10 V control signal.

In the event of a power failure of more than 5 seconds, the actuator will return mechanically to its 0 % stroke position within 30 seconds, closing the valve (A → AB).

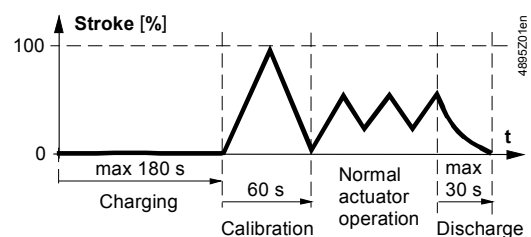

## Self-calibration

SSC61 and SSC61.5

When the AC / DC 24 V supply is applied for the first time, the actuators calibrate themselves independent of the control signal. In this process, the actuator drives the valve to the mechanical end stops and stores the associated positions permanently in the form of electronic values. The positioning signal is only active on completion of this calibration process. Calibration takes about 60 seconds.  
The SSC61.5 only performs self-calibration when the charging process is completed.

## Recalibration

If the calibrated actuator is used with some other valve (e.g. a replacement valve), it must be recalibrated.

1. Unscrew screws
2. Remove cover
3. Connect the 2 contacts behind the slot for about 1 second.

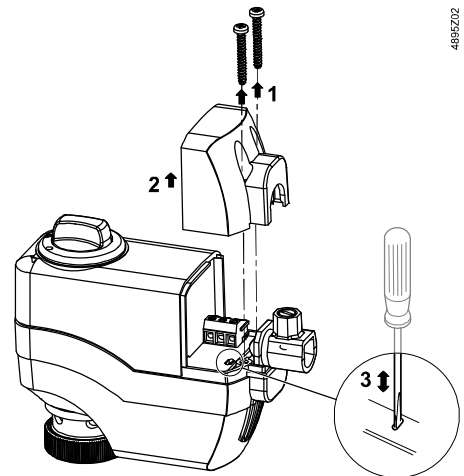

The calibration can only be made correctly if the actuator is fitted to a valve (refer to «Equipment combinations», page 2).

## Features and benefits

- Plastic cover
- Position indication
- Locking-proof, maintenance-free gear train
- Manual adjustment with rotary knob
- Reduced power consumption in the holding positions
- Load-dependent switch-off in the event of overload and in stroke end positions
- Parallel operation of 10 SSC.. possible, provided the controllers' output is sufficient

## Accessories

### Mounting kit



Type ASK30

Mounting kit for Landis & Gyr valves VVG45..., VXG45... and X3i..

## Notes

### Engineering

The actuators must be electrically connected in accordance with local regulations (refer to «Connection diagrams», page 6).



**Regulations and requirements to ensure the safety of people and property must be observed at all times!**

The permissible temperatures must be observed (refer to «Technical data», page 5).

### Mounting

Mounting Instructions 74 319 0260 0 are enclosed with each pack.

Assembly is made with the coupling nut; no tools or adjustments are required. The actuators should be installed so that they are initially in position 0 (also refer to «Manual override», page 4).

Orientation

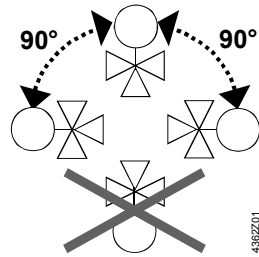

Commissioning

When commissioning the system, check wiring and the functions of the actuator.

**⚠ Caution**

**Before testing the functioning of the SSC..., always check to ensure that the actuator concerned is mounted on a valve (refer to «Equipment combinations», page 2).**

Calibrating the SSC61 or SSC61.5 without a valve connected causes the actuator to lock in position 1. To recalibrate (after mounting on a valve), disconnect power and reset the stroke manually from position 1 to 0 (refer to «Recalibration», page 3).

Operation

The rotary knob can be used to drive the actuator into any position between 0 and 1. If a control signal from the controller is present, this will take priority in determining the position.

Note

To retain the manually set position, unplug the connecting cable or switch off the rated voltage and the control signal. Due to the reset function, the SSC61.5 will first travel to position 0 and can then be driven manually to the required position.

Manual override

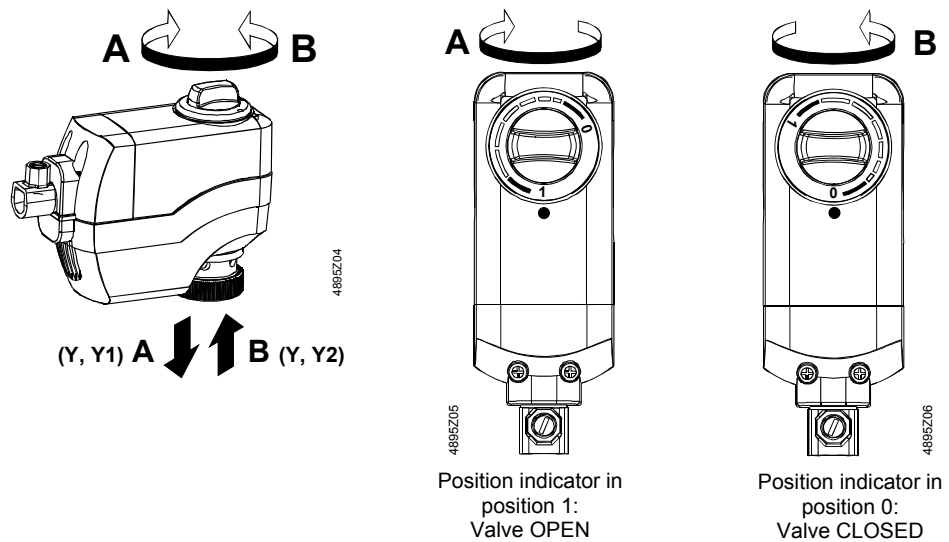

Note SSC61...

After manual override with the rotary knob the positioning signal and the stroke synchronize autonomously, if the positioning signal is once > 9.7 V or < 0.3 V.

Maintenance

When servicing the actuator:

- Switch off power
- If necessary, disconnect the terminals
- The actuator must only be commissioned with a correctly mounted valve in place!

Repair

The SSC.. actuators cannot be repaired. They must be replaced as a complete unit.

Disposal



The device must not be disposed of together with domestic waste. This applies in particular to the PCB.

Legislation may demand special handling of certain components, or it may be sensible from an ecological point of view.

**Current local legislation must be observed.**

## Warranty

The technical relating to specific applications are valid only in conjunction with the Siemens valves listed in this Data Sheet under «Equipment combinations», page 2.

**The use of the SSC... actuators in conjunction with third-party valves invalidates any warranty offered by Siemens Building Technologies / HVAC Products.**

## Technical data

		SSC31	SSC81	SSC61	SSC61.5	
Power supply	Rated voltage	AC 230 V	AC 24 V	AC 24 V or DC 24 V		
	Voltage tolerance	± 15 %	± 20 %	± 20 %	± 25 %	
	Rated frequency	50 / 60 Hz				
	Max. power consumption	6 VA	0.8 VA	2 VA	2 VA <sup>1)</sup>	
	⚠ Fuse for incoming cable (fast)	2 A				
Control	Control signal	3-position		DC 0...10 V		
	Input impedance for DC 0...10 V			> 100 kOhm		
	Positioning accuracy for DC 0...10 V			< 2 % of nominal stroke		
	Parallel operation (number of actuators) <sup>2)</sup>	max. 10				
Functional data	Running time for 5.5 mm stroke at 50 Hz	150 s		30 s		
	Capacitor charging time				max. 180 s	
	Fail-safe run time				30 s	
	Nominal stroke	5.5 mm				
	Nominal force	300 N				
	Permissible temperature of medium in the connected valve	1...110 °C				
Electrical connections	Terminal block, pluggable	screw terminals for max. 3 mm <sup>2</sup>				
	Terminal block color	green	grey	red	red	
	Cable strain relief	for cables 4...11 mm dia.				
Standards	Meets requirements for CE marking: EMC directive	2004/108/EC				
	Immunity	EN 61000-6-2		Industrial <sup>3)</sup>		
	Emission	EN 61000-6-3		Residential		
	Low voltage directive	2006/95/EC				
	Electrical safety	EN 60730-1				
	Protection class to EN 60730	II		III		
	Contamination level	EN 60730, Class 2				
Housing protection	Upright to horizontal	IP40 to EN 60529				
	UL approbation	UL 873				
	cUL approbation	C22.2 No. 24-93				
	Environmental compatibility	ISO 14001	(environment)			
		ISO 9001	(quality)			
SN 36350		(environmentally compatible products)				
RL 2002/95/EG (RoHS)						
Dimensions / weight	Dimensions	refer to «Dimensions», page 7				
	Coupling thread to valve	coupling nut G <sup>3</sup> / <sub>4</sub> inch				
	Weight	0.26 kg	0.25 kg	0.27 kg		
Housing colors	Base, rotary knob	RAL 7035, light-grey				
	Cover	RAL 5014, pigeon-blue				

<sup>1)</sup> 3 VA, when capacitor charged for automatic reset

<sup>2)</sup> Provided the controllers' output is sufficient

<sup>3)</sup> Transformer 160 VA (e.g. Siemens 4AM3842-4TN00-0EA0) for AC 24 V actuators

**General ambient conditions**

	<b>Operation</b> EN 60721-3-3	<b>Transport</b> EN 60721-3-2	<b>Storage</b> EN 60721-3-1
Environmental conditions	class 3K3	class 2K3	class 1K3
Temperature	+5...+50 °C	-25...+70 °C	-25...+70 °C
Humidity	5...95 % r.h.	< 95 % r.h.	5...95 % r.h.

**Connection terminals**

SSC31	<div style="display: flex; flex-direction: column; align-items: center;"> <div style="border: 1px solid black; padding: 2px; margin-bottom: 2px;">Y2</div> <div style="border: 1px solid black; padding: 2px; margin-bottom: 2px;">Y1</div> <div style="border: 1px solid black; padding: 2px;">N</div> </div>	Control signal CLOSE (AC 230 V) Control signal OPEN (AC 230 V) Neutral	
SSC81	<div style="display: flex; flex-direction: column; align-items: center;"> <div style="border: 1px solid black; padding: 2px; margin-bottom: 2px;">Y2</div> <div style="border: 1px solid black; padding: 2px; margin-bottom: 2px;">Y1</div> <div style="border: 1px solid black; padding: 2px;">G</div> </div>	Control signal CLOSE (AC 24 V) Control signal OPEN (AC 24 V) System potential AC 24 V	
SSC61 SSC61.5	<div style="display: flex; flex-direction: column; align-items: center;"> <div style="border: 1px solid black; padding: 2px; margin-bottom: 2px;">Y</div> <div style="border: 1px solid black; padding: 2px; margin-bottom: 2px;">G</div> <div style="border: 1px solid black; padding: 2px;">G0</div> </div>	Control signal DC 0...10 V System potential AC 24 V System neutral	(+ with DC 24 V) (- with DC 24 V)

**Connection diagrams**

SSC31

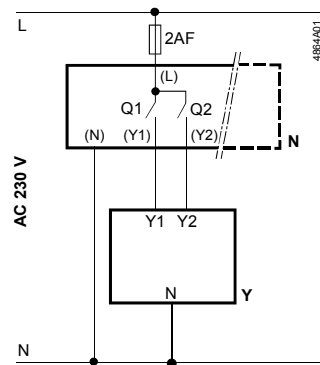

N Controller  
 Y Actuator  
 L System potential AC 230 V  
 N System neutral  
 Y1, Y2 Control signal OPEN, CLOSE  
 Q1, Q2 Controller contacts

SSC81

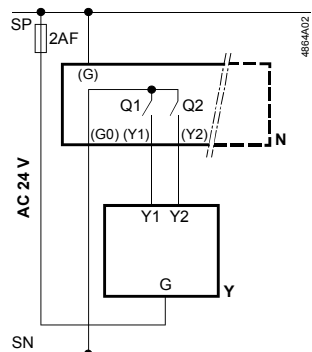

N Controller  
 Y Actuator  
 SP, G System potential AC 24 V  
 SN, G0 System neutral  
 Y1, Y2 Control signal OPEN, CLOSE  
 Q1, Q2 Controller contacts

SSC61  
SSC61.5

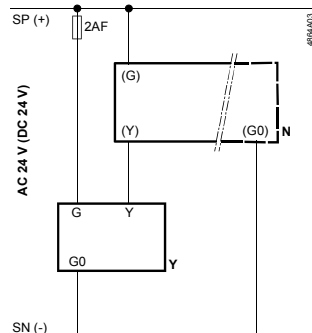

N Controller  
 Y Actuator  
 SP G System potential AC / DC 24 V  
 SN, G0 System neutral  
 Y Control signal

## Dimensions

All dimensions in mm

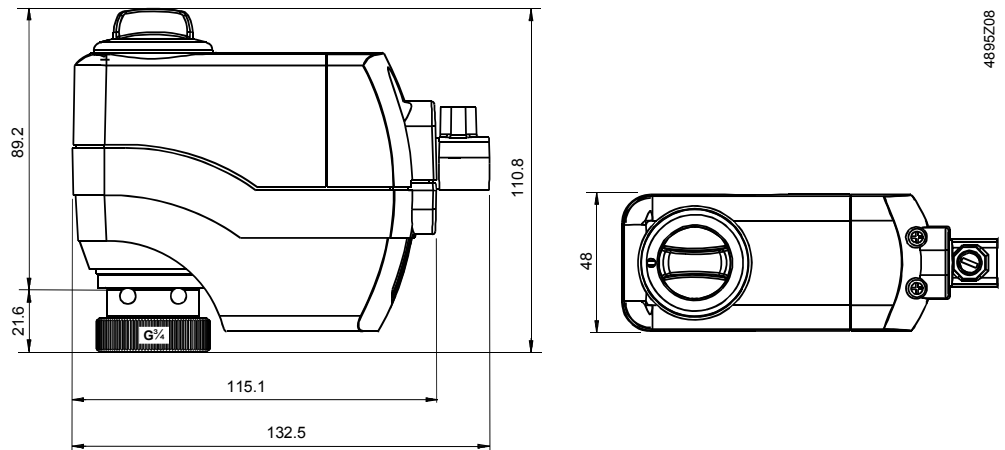

## Revision numbers

Type reference	Valid from Rev.-No.	Type reference	Valid from Rev.-No.
SSC31	J	SSC61	J
SSC81	J	SSC61.5	J

