

Binary input device N 264E11
8x AC/DC 12...230 V + 8x potential-free contacts

5WG1 264-1EB11

??Product and function description



The binary input device N 264E11 is a N-system DIN-rail mounted device with 8 inputs (a...h) for potential-free contacts and 8 inputs (A...H) for AC or DC voltages in the range 12...230 V. It supports the monitoring of the input status (contact closed or open resp. voltage applied or not) and the detection of changes of status (contact was opened or closed resp. voltage was coming or going). It can therefore be used to monitor voltages (for example whether mains voltage is present), to record switching or operating states of plants (whether a plant is switched on or off, whether a limit violation or a malfunction or an alarm is being signalled), to record the change of status when switching on or switching off (whether a switch or a pushbutton was activated, whether it was activated for a shorter or longer period) and to record and count changes of the switching status resp. voltage pulses with a minimum on-time of the contact resp. of the voltage of 70 ms and a max. pulse succession of up to 5 pulses per second, without or with monitoring of the number of pulses counted until a predetermined threshold has been reached or exceeded.

At each input a red LED shows (LED = on) whether a voltage is applied or the connected contact closed. The N 264E11 has an integrated 230 V power supply in order to supply the electronics. This power supply enables the generation of the voltage pulses for checking the switching statuses and for displaying the signal statuses at the inputs via the LEDs even when there is no bus voltage present.

Note: The device is without function after the application program has been "unloaded" with the ETS. The status of the inputs is also no longer displayed in this case.

Application program

The "25S16 Binary Input Device 980D01" application program, which can be downloaded with the ETS2 V1.3, supports a multitude of applications and enables one of the following functions to be assigned to every input:

- Switching status / binary value transmission
- Switching, edge-triggered
- Switching, short / long operation
- 1-button dimming
- 1-button solar protection control
- 1-button group control (sequence control)
- 1-bit Scene control
- 8-bit Scene control
- 8-bit value, edge-triggered
- 8-bit value, short / long operation
- 16-bit floating point value, edge-triggered
- 16-bit floating point value, short / long operation
- 8-bit pulse counting without threshold check
- 8-bit pulse counting with threshold check
- 16-bit pulse counting without threshold check
- 16-bit pulse counting with threshold check
- 32-bit pulse counting without threshold check
- 32-bit pulse counting with threshold check.

Using the ETS, one of the following functions can be allocated to one input pair, i.e. to two neighbouring inputs:

- 2-button dimming with stop telegram
- 2-button solar protection control.

Connection example

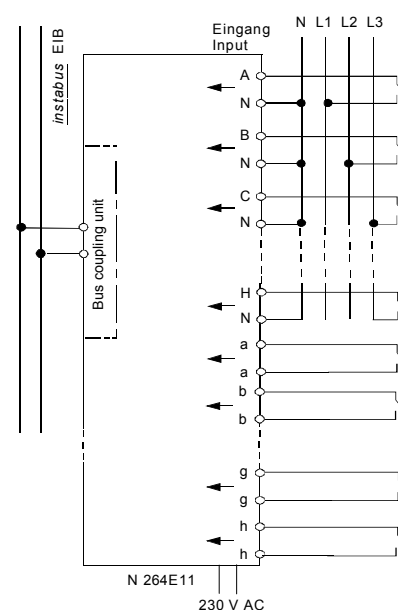

Binary input device N 264E11
8x AC/DC 12...230 V + 8x potential-free contacts
5WG1 264-1EB11**Installation notes**

- The device can be used for permanent installation in dry interior rooms and for insertion in control cabinets or small distribution boards.

**DANGER**

- Never connect an AC or DC voltage to one of the inputs a...h for potential-free contacts (this will damage / destroy the input / device and impress this voltage on the bus).
- Basic insulation for 250 V has to be kept when connecting the potential-free contacts to the terminals a...h.
- The device must only be installed and commissioned by an authorized professional electrician.
- Unoccupied sections of DIN rail with data rail inserted must be protected with the cover 5WG1 192-8AA01.
- When connecting the device, care should be taken that the device can be isolated from the mains.
- The device must not be opened.
- When planning and installing electrical equipment the relevant guidelines, regulations and specifications of the respective country must be considered.

Technical data**Power supply**

- Bus voltage: via the bus line
- Bus current: 5 mA (only half standard bus load!)
- Electronics:
 - integrated power supply for AC 230V, +10%/-15%, 50Hz
 - Mains connection: 2-pole (N, L)
 - power consumption: max. 1.7 W

Operating elements:

- 1 commissioning pushbutton: for toggling between normal mode / addressing mode

Display elements

- 1 red LED: for checking the bus voltage and displaying normal mode / addressing mode
- 1 green LED: for displaying the 230 V operating voltage
- 1 red LED per binary input for status display; LED = ON: voltage is present at the input resp. contact is closed.

Inputs

- 8 inputs a...h for potential-free contacts (with basic insulation 250 V against each other and against the bus)

- Detection of the switching status of a floating contact connected to an input by means of voltage pulses generated by the device:
 - pulse voltage when the contact is open: typ. 15 V_{SS}
 - pulse current when the contact is closed: typ. 0.45 A_{SS}
- Input signal delay till transmission of first bus telegram:
 - after closing the contact: 100 ms
 - after opening the contact: 100 ms
- Contact closed time: min. 100 ms
- Contact open time: min. 100 ms
- max. detectable switching frequency: 5 Hz
- Input function: to be set in the parameter list
- Max. length of connecting cable with wires twisted in pairs: 100 m
- 8 voltage inputs A...H for AC/DC 12 V ... 230 V (with basic insulation 250 V against each other and enhanced insulation against the bus)
 - (U_{in} = 0...2 V: = no voltage applied = log. 0;
 - U_{in} ≥ 9 V: = voltage applied = log. 1)
- **Note:** In case of a DC voltage the negative pole has to be connected to the terminal marked with "N".
- Input current:
 - at max. AC 253 V: typically 1.5 mA (RMS)
 - at max. DC 253 V: typically 3.0 mA
- Input signal delay:
 - at leading edge of input signal:
 - max. 60 ms at DC
 - max. 100 ms at AC
 - at trailing edge of input signal:
 - max. 140 ms at DC
 - max. 100 ms at AC
- Input signal ON-time: min. 60 ms at DC
min. 100 ms at AC
- Input signal OFF-time: min. 140 ms at DC
min. 100 ms at AC
- Max. detectable switching frequency: 5 Hz
- Input function: to be set in the parameter list
- Signal line length: max. 100 m

Connections

- Mains connection and inputs:
 - Plug-in terminals, insulation strip length 9...10 mm
- **Note:** Cables with wires twisted in pairs should be used when connecting potential-free contacts to the inputs of the actuator.
- The following conductor cross-sections are permitted:
 - 0,5 ... 2.5 mm² single-core
 - 0,5... 2.5 mm² finely stranded with plug connector, sealed crimp connection
 - 0,5 ... 1.5 mm³ finely stranded, with connector sleeve
 - 1.0 and 1.5 mm² finely stranded, untreated

Binary input device N 264E11
8x AC/DC 12...230 V + 8x potential-free contacts
5WG1 264-1EB11

- KNX bus line:
 - Pressure contacts on data rail,
 - Screw-less bus terminal, 0.6 ... 0.8 mm Ø single-core, insulation strip length 5 mm

Mechanical data

- Housing: plastic
- Dimensions: DIN rail mounted device in N-system dimensions, width 6 Module Units (1 MU = 18 mm)
- Weight: approx. 325 g
- Fire load: approx. 6113 kJ
- Mounting: Snap-on mounting on DIN rail EN 60715-TH35-7.5

Electrical safety

- Degree of pollution (according to IEC 60664-1): 2
- Type of protection (according to EN 60529): IP 20
- Overvoltage category (according to IEC 60664-1): III
- Bus: Safety extra-low voltage SELV DC 24 V
- Device complies with EN 50090-2-2

EMC requirements

- Complies with EN 50090-2-2 and EN 61000-6-2

Environmental conditions

- Climatic withstand capability: EN 50090-2-2
- Ambient operating temperature: - 5 ... + 45 °C
- Storage temperature: - 25 ... + 70 °C
- Rel. humidity (not condensing): 5 % to 93 %

Markings:KNX *EIB***CE mark**

In accordance with the EMC guideline (residential and functional buildings), low voltage guideline

Position and function of the display and operating elements

Figure 1: Position of the display and operating elements

- A1 Button for toggling between normal mode / addressing mode for transferring the physical address
- A2 LED for displaying normal mode (LED Off) or addressing mode (LED On); it is automatically extinguished once the physical address has been transferred
- A3 Plug for bus connecting terminal
- A4 LEDs for status display of inputs a to h
- A5 LEDs for status display of inputs A to H
- A6 Terminals for inputs a to h
- A7 Terminals for inputs A to H
- A8 Terminals for L-conductor and neutral conductor (N) for power supply of the electronics
- A9 LED for displaying the operating voltage

Installation and wiringGeneral description

The DIN rail mounted device in N-system dimensions (width 6 module units) can be inserted in N-system distribution boards, surface- or flush-mounted and wherever DIN rails according to EN 60715-TH35-7.5 are present.

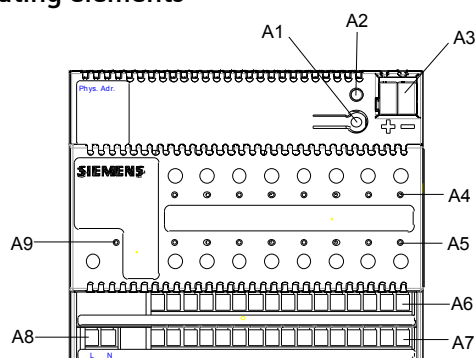
Installing the DIN rail mounted device (Figure 2)

- Suspend the DIN rail mounted device (B 1) on the DIN rail (B 2) and
- Rotate the DIN rail mounted device (B1) backwards until the slide switch audibly clicks into position.

Dismantling the DIN rail mounted device (Figure 2)

- Press the slide switch (C3) downwards with a screwdriver and
- Remove the DIN rail mounted device (C1) from the DIN rail (C2) with a swivel action.

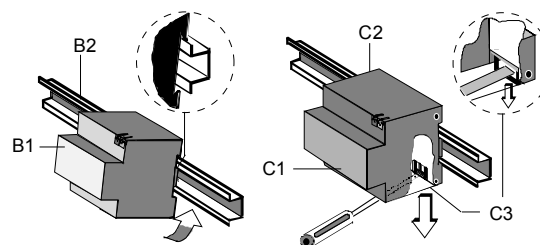

Figure 2: Installing / dismantling the device

Removing the bus terminal (Figure 3)

- The bus terminal (D2) is located on the upper side of the binary input device N 264E11 (D1).
- The bus terminal (D2) consists of two sections (D2.1, D2.2) each with four terminal contacts. Care should be taken not to damage the two test sockets (D2.3) either

**Binary input device N 264E11
8x AC/DC 12...230 V + 8x potential-free contacts**

5WG1 264-1EB11

by accidentally trying to put in the bus cable or with the screwdriver (when trying to remove the bus terminal).

- Carefully insert the screwdriver into the wire entry slot underneath the bus terminal (D2) and pull the bus terminal (D2) forwards out of the binary input device (D1).

Note:

Care should be taken as there is a risk of shorting the bus pins with the screwdriver!

Attaching the bus terminal (Figure 3)

Insert the bus terminal (D2) into the guide slot and press the bus terminal backwards until it reaches the stop position.

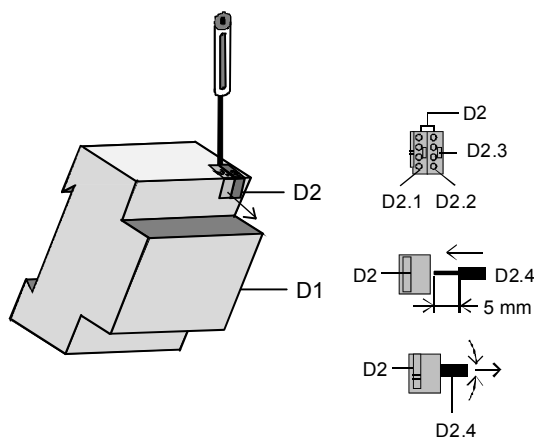

Figure 3: Attaching / removing the bus terminal

Mounting the insulating cap

If the device is to be mounted on a DIN rail without a data rail, then the contact system must be covered using the supplied insulating cap.

Removing the locating clamp (Figure 4)

- The locating clamp (E3) encloses the contact system (E2) on the rear of the device (E1).
- Insert the screwdriver between the DIN rail mounted device (E1) and the locating clamp (E3) and remove the clamp.

Clipping on the insulating cap (Figure 4)

- Place the insulating cap (E4) on the contact system and press so that it snaps into place.

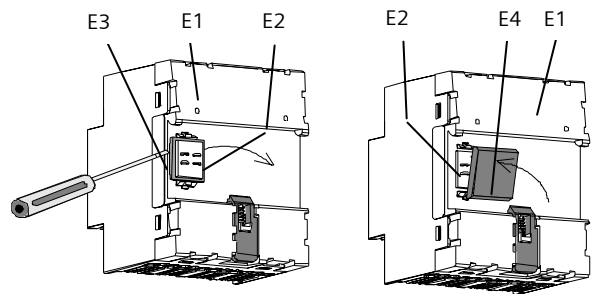
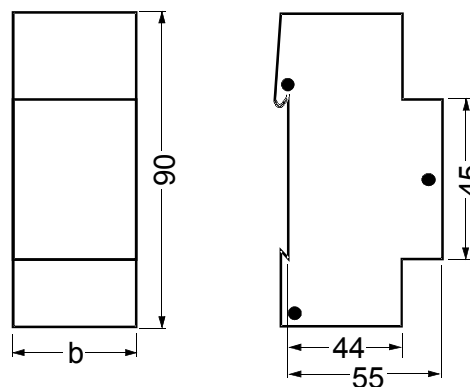

Figure 4: Covering the contact system

Dimension drawing

Dimensions in mm.



b = 6 module units

1 module unit (MU) = 18 mm

General notes

- Any faulty device should be returned to the local Siemens office.
- If you have further questions concerning the product, please contact our Technical Support:
 - +49 (0) 180 50 50-222
 - +49 (0) 180 50 50-223
 - www.siemens.com/automation/support-request